

**1995
WCD25RU**

**FB1
FC1**

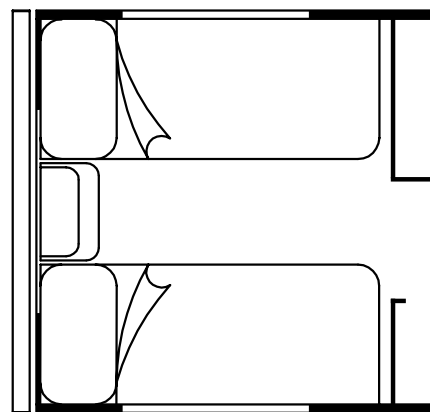
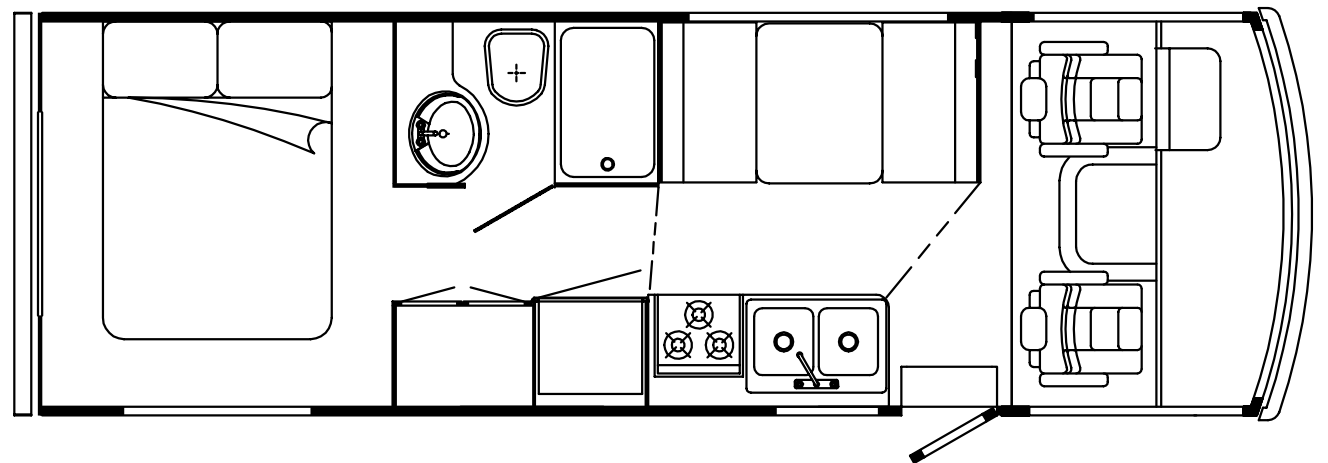
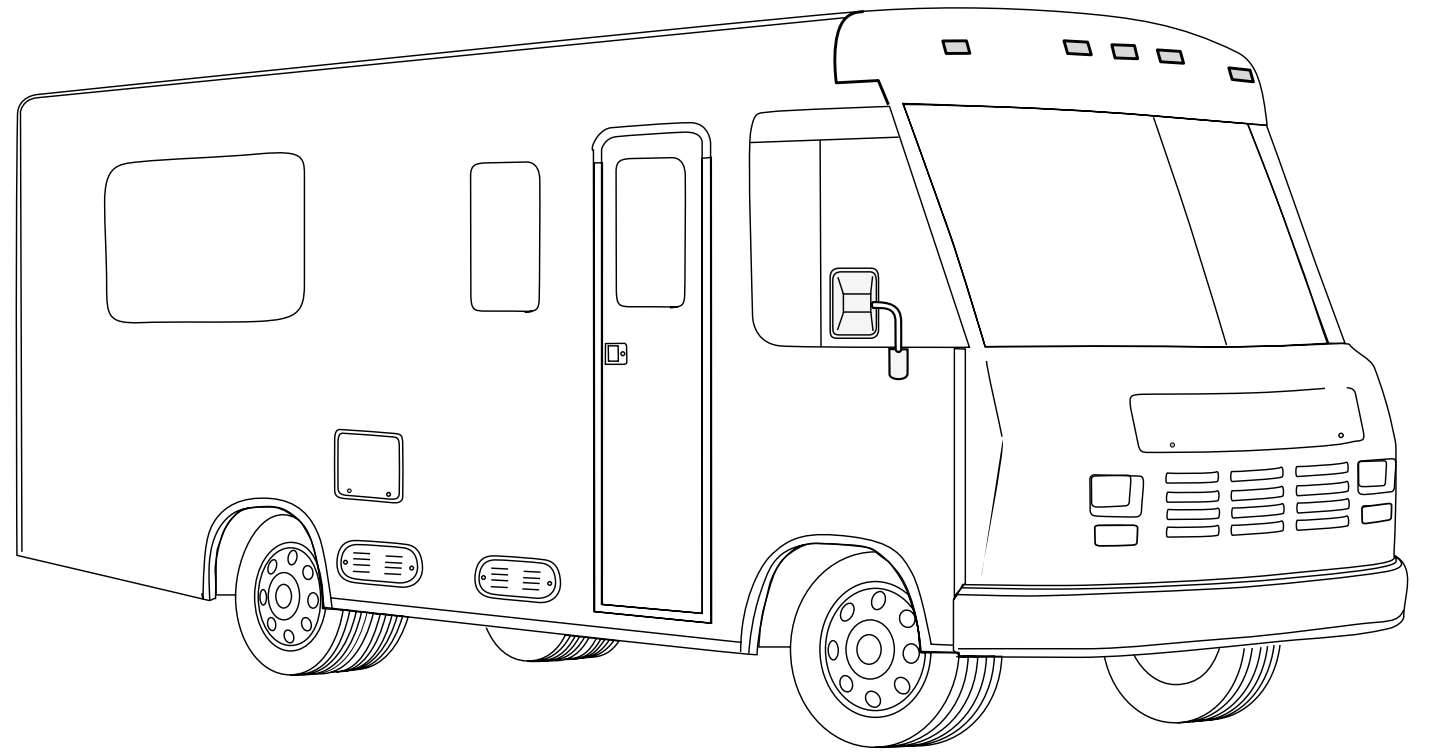

ACCESSORIES GROUP

OPERATOR MANUAL

KEY	PART NUMBER	U/M DESCRIPTION
	054185-C4-000	EA MANUAL-OPERATOR 95 WARRIOR D-SERIES
	092318-01-000	EA BINDER - 3 RING, MOTOR HOME MANUAL
	092319-01-000	EA POCKET PAGE - 3 RING BINDER, PLASTIC
	115209-01-000	DW TOP LEVEL DRAWING, 1995 D-SERIES

AUDIO VIDEO GROUP

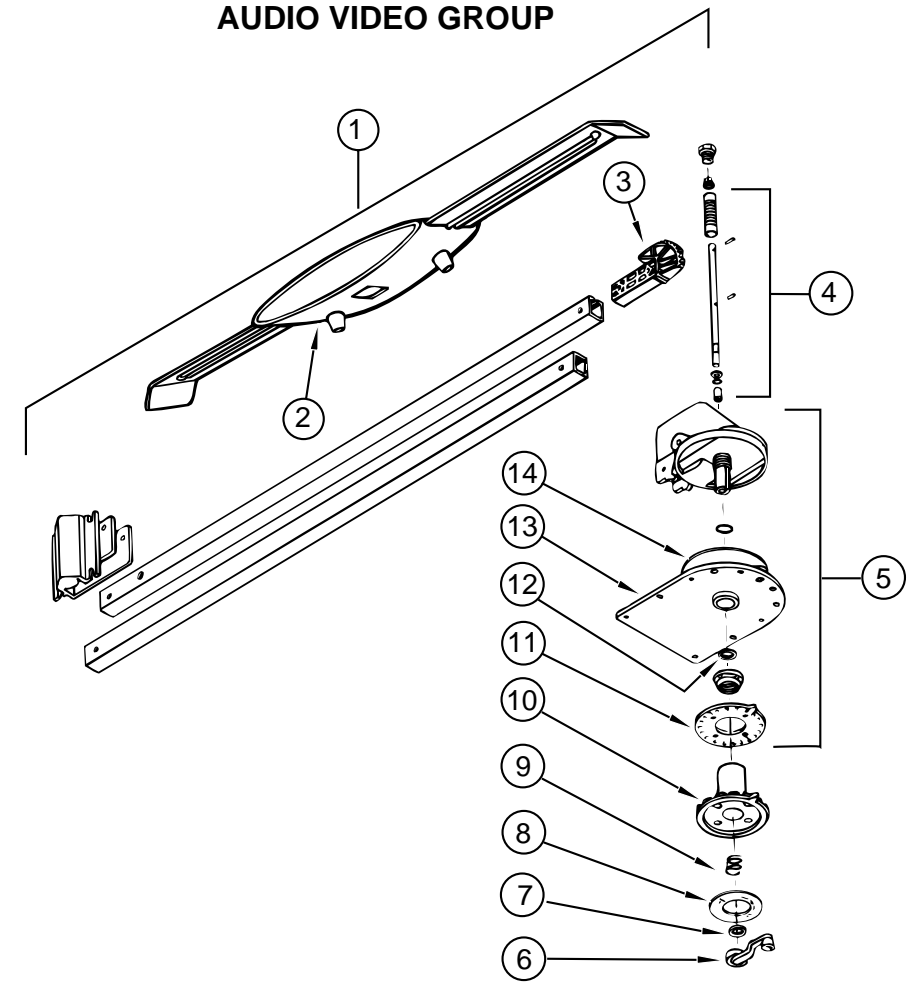

TV ANTENNA

KEY	PART NUMBER	U/M DESCRIPTION
1	076319-01-000	EA ANTENNA - TV - ROOF MOUNT
2	076319-01-700	EA HEAD - ANTENNA - AMPLIFIED - WINEGARD - RVSA U/V
3	076319-01-701	EA GEAR - ELEVATING - PLASTIC - WINEGARD - 2200046
4	076319-01-702	EA SHAFT ASM - ELEVATING - WINEGARD - RVP-400A
5	076319-01-711	EA BASE & LIFT ASM - WINEGARD - 2762802
6	076319-01-706	EA CRANK - ELEVATING - W/ SET SCREW - WINEGARD - 5755100
7	076319-01-705	EA BEARING - NYLON - 7/8"ID - WINEGARD - 3200658
8	076319-01-708	EA CRANK COVER DECAL - WINEGARD - 5413002
9	076319-01-707	EA SPRING - HANDLE - WINEGARD - 5160822
10	076319-01-709	EA PLATE - DIRECTIONAL - FOR HEAD - WINEGARD - 3200644
11	076319-01-712	EA CEILING PLATE - WINEGARD - 3200608
12	076319-01-704	EA BEARING - NYLON - 1.5"OD - WINEGARD - 3200657
13	076319-01-713	EA BASE PLATE - WINEGARD - 3100523
14	076319-01-703	EA BEARING - NYLON - 5"OD - WINEGARD - 3200656
	076319-06-000	EA ADAPTOR-CABLE ROOF PLATE, WINEGARD RPJ-1
	076319-03-000	FT CABLE-COAXIAL, 75 OHM
	076319-12-000	EA CONNECTOR-COAXIAL, ONE PIECE
	086777-01-000	EA PLATE-WALL, CABLE - W/TV ANTENNA SWITCH - IVORY

RADIO SYSTEM & ANTENNA

KEY	PART NUMBER	U/M DESCRIPTION
	087683-02-000	EA RADIO-AM/FM STEREO W/CASSETTE, AUDIOVOX P-1A
	110743-01-000	EA SPEAKER-RADIO, FADER CONTROL - ASA 1410000
	110469-01-000	EA SPEAKER - 4" X 6", OVAL - MAGNADYNE F46XB-12
	110470-01-01A	EA GRILLE-SPEAKER, OVAL - 4" X 6" - BLACK - MAGNADYNE G46WI
	N/A	EA SPEAKER, 5" X 7" - FORD F2UF-18814-CD (OVERHEAD CABINETS)
	077069-02-000	EA CABLE-ANTENNA, RADIO - EXTENSION 96" - ARA 6700667
	090944-01-000	EA ANTENNA-RADIO, 16" RUBBER
	110272-01-000	EA BRACKET-ANTENNA
	081059-02-000	EA WIRE ASM - 9-PIN, RADIO - AUDIOVOX 112B-1761

BATH GROUP

BATHROOM CABINET & COMPONENTS

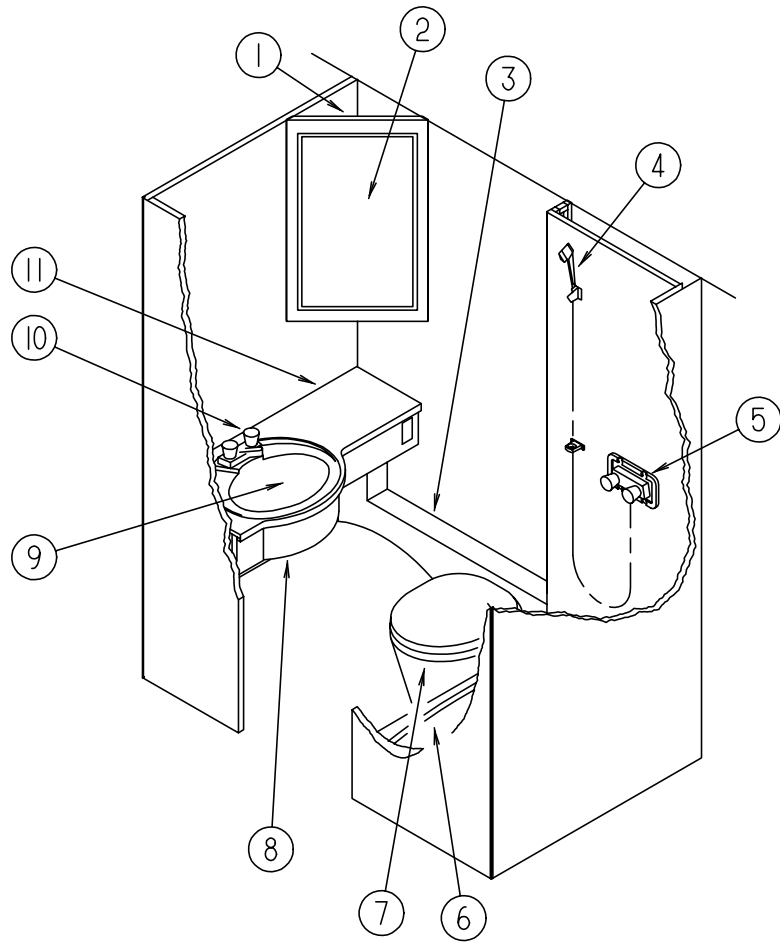

KEY	PART NUMBER	U/M	DESCRIPTION
1	110341-01-EB1	EA	CABINET ASM-MEDICINE
2	110140-13-EB1	EA	DOOR ASM-MITERED - VINYL WRAP
	058331-85-000	EA	MIRROR-GLASS - SAFETY - 530 MM X 900 MM
3	P10276-01-000	EA	CABINET ASM-PIPE COVER - W/O CARPET
4	103092-01-000	EA	SHOWER HEAD-W/60" HOSE
4	103092-02-000	EA	SHOWER HEAD-W/HOSE - ONDINE 23213NYLON B
4	103092-01-700	EA	BRACKET ONLY-CLEAR - FOR SHOWER HEAD - 2328028
5	109801-01-01A	EA	FAUCET-SHOWER CONTROL - PARCHMENT - BPC 20-154P01
	075606-01-000	EA	PANEL-FAUCET BACK - SHOWER - 5" X 9" - PLASTIC
6	M02630-22-C07	EA	SHOWER PAN ASM
	066440-01-000	EA	STRAINER-SHOWER - W/RUBBER WASHER
	069735-01-000	EA	WASHER-STRAINER TO TAILPIECE PLASTIC - 1.5"
7	063740-01-000	EA	TOILET-HIGH - HAND FLUSH - THETFORD 150120
	063740-01-700	EA	LEVER-WATER - THETFORD 12514
	063740-01-701	EA	LEVER-FLUSH - THETFORD 12515
	063740-01-706	EA	BOLT PACKAGE-CLOSET - THETFORD 12524
	063740-01-710	EA	LINK - THETFORD 12513
	063740-01-711	EA	SPRING-RETURN LEVER - THETFORD 12523
	063740-01-713	EA	SEAL-BALL VALVE TO BOWL - THETFORD 12502
	063740-01-714	EA	VALVE ASM-WATER - THETFORD 12492
	063740-01-716	EA	SEAT & COVER - IVORY - THETFORD 15017
	063740-01-717	EA	TUBE-FLUSH - TOILET - THETFORD 12509
	063740-02-700	EA	SEAT & COVER - PARCHMENT - THETFORD 20829
	024676-01-000	EA	FLANGE-CLOSET - TOILET - 4" X 3" - RED
	024676-02-000	EA	FLANGE-CLOSET - 4" X 3" - ABS - CANADIAN
8	P10118-01-FB1	EA	CABINET ASM-LAVATORY
9	109683-01-01A	EA	SINK-LAVATORY - LARGE OVAL - 17 X 20 - BPC 16370PP OFF WHITE
	106116-01-01A	EA	STRAINER-SINK - W/STOPPER TAILPIECE GASKET & NUT - PLASTIC
10	109800-01-01A	EA	FAUCET-LAVATORY - PARCHMENT - BPC 20-177P01
	105218-01-01A	EA	SPACER-FAUCET - LAVATORY SINK - 2" X 5.9" - OFF WHITE
11	110118-11-FB1	EA	COUNTERTOP ASM
	075452-02-000	EA	HOLDER-TOILET TISSUE - BRASS
	075453-02-000	EA	BAR-TOWEL - 18" BRASS
	100494-04-EB1	EA	DOOR ASM-BATH
	084451-01-000	EA	CATCH-BATH DOOR - BRASS
	058335-02-000	EA	LATCH-BATHROOM DOOR - WITHOUT LOCK
	009151-01-000	EA	GUARD-WARP - CABINET/PRIVACY DOOR - 48"
	057671-01-000	EA	COVER-SCREW, NO 8

BEDROOM GROUP

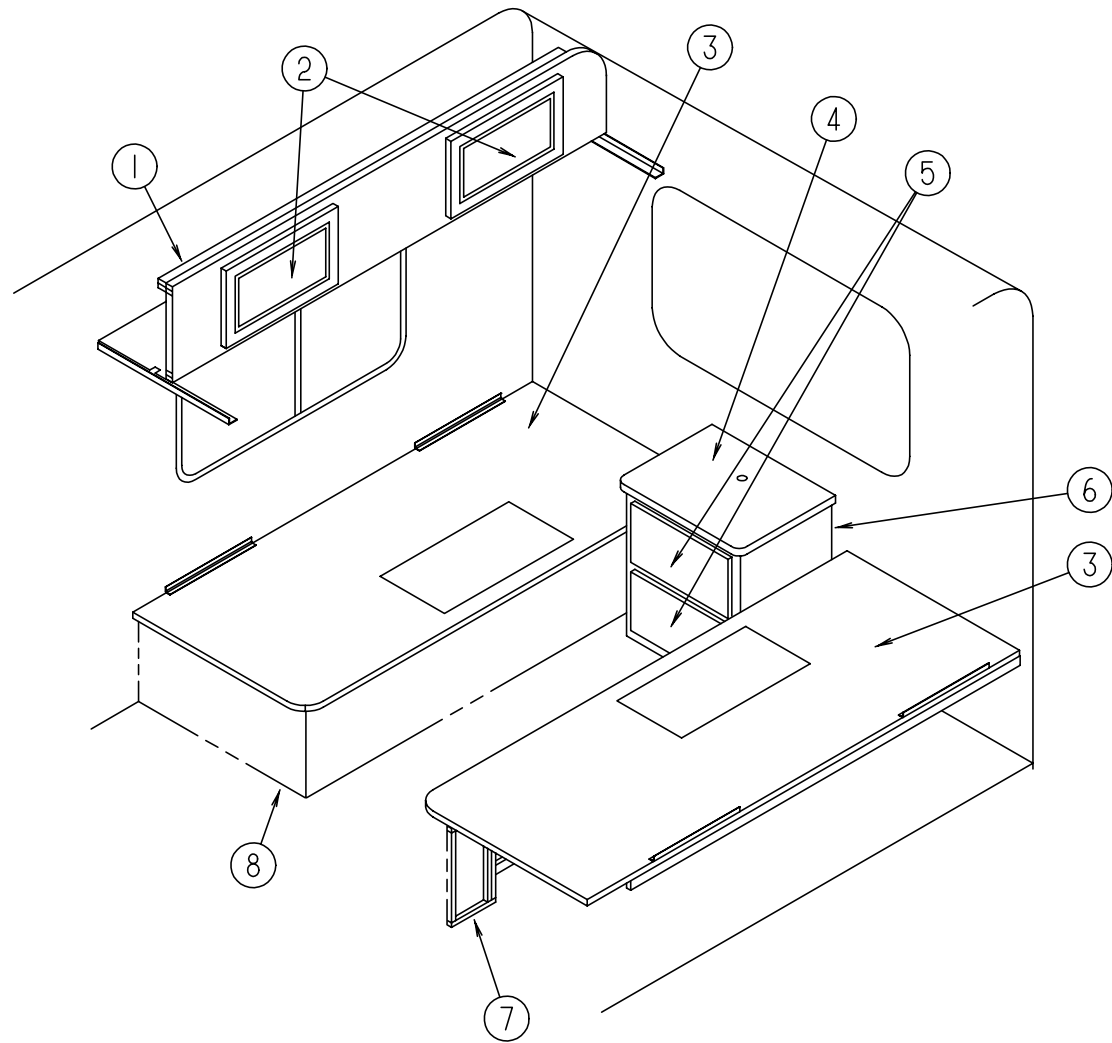

TWIN BEDROOM

KEY	PART NUMBER	U/M	DESCRIPTION
1	P12327-01-FB1	EA	CABINET ASM-OVERHEAD - BUNK - RIGHT
	P12327-02-FB1	EA	CABINET ASM-OVERHEAD - BUNK - LEFT
2	M05930-14-FB1	EA	DOOR ASM-MITERED - VINYL WRAP
3	M05138-13-FB1	EA	CABINET ASM-TWIN BED TOP - PASSENGER
3	M05138-14-FB1	EA	CABINET ASM-TWIN BED TOP - DRIVERS
4	112305-11-FB1	EA	COUNTERTOP ASM
5	P10163-09-EB1	EA	DRAWER COMPLETE-SLIDE
6	112305-01-EB1	EA	CABINET ASM-NIGHTSTAND
7	P15169-01-FB1	EA	CABINET ASM-BED - TWIN - LEFT
8	P15169-02-FB1	EA	CABINET ASM-BED - TWIN - RIGHT
	098442-02-EB1	EA	LEG ASM-BED

BEDROOM GROUP (CONTINUED)

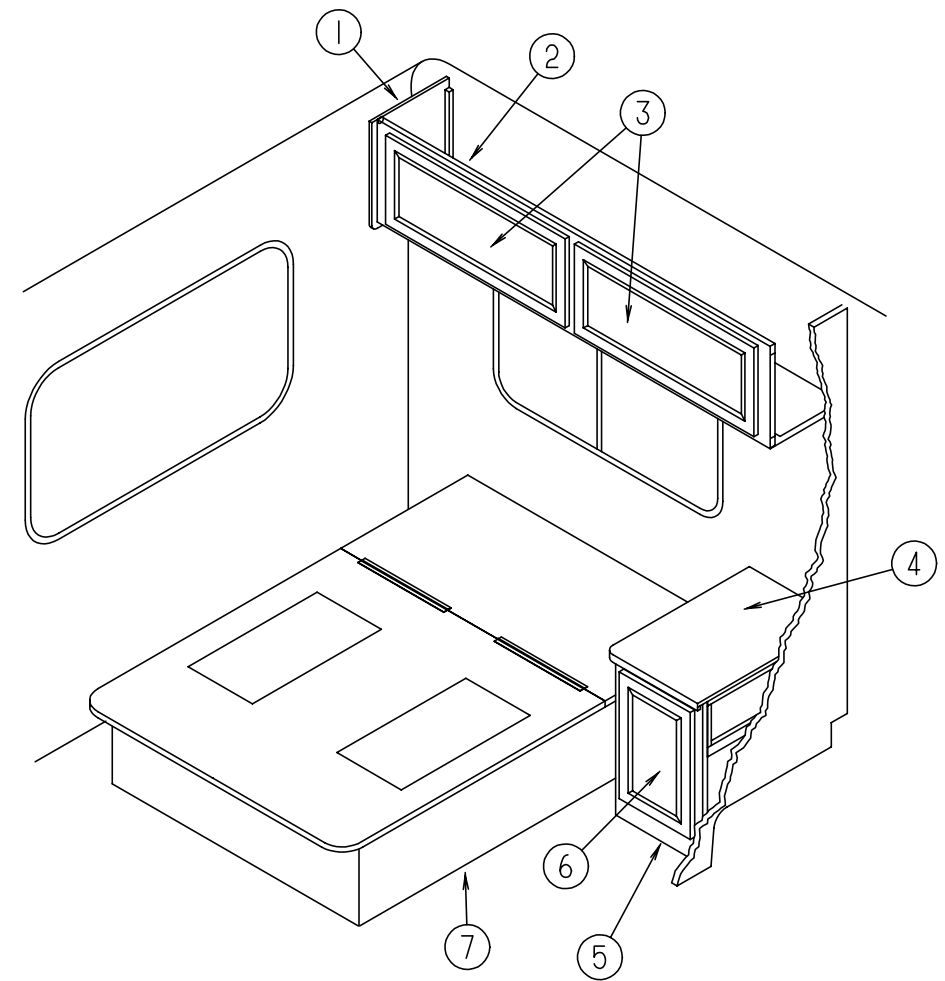

DOUBLE BEDROOM

KEY	PART NUMBER	U/M	DESCRIPTION
1	109908-04-EB1	EA	CAP ASM-END - OVERHEAD
2	M07447-03-FB1	EA	CABINET ASM-OVERHEAD
3	110140-65-F15	EA	DOOR ASM-MITERED - VINYL WRAP
	108536-13-08A	EA	MIRROR - GLASS GALAXY FLOWER
4	112304-11-FB1	EA	COUNTERTOP ASM
5	112304-01-FB1	EA	CABINET ASM-NIGHTSTAND
6	M05930-07-EB1	EA	DOOR ASM-MITERED - VINYL WRAP
7	P15127-01-FB1	EA	CABINET ASM-BED
	098442-02-EB1	EA	LEG ASM-BED

CHASSIS GROUP

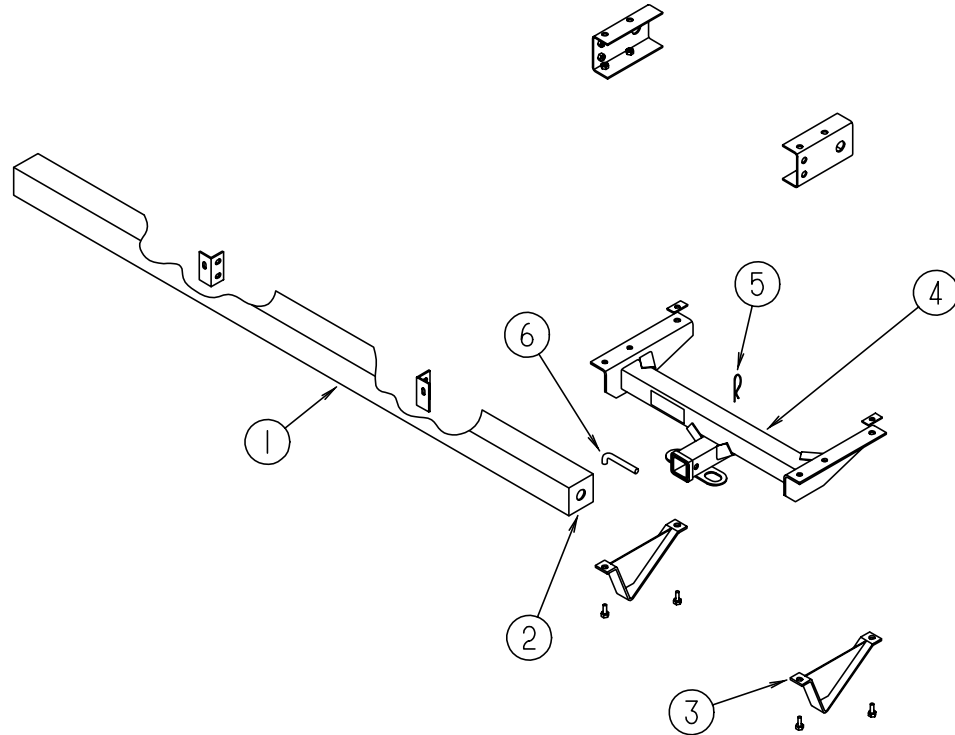

REAR BUMPER, TRAILER HITCH & COMPONENTS

KEY	PART NUMBER	U/M DESCRIPTION
1	110231-01-DB1	EA BUMPER ASM-REAR
2	039779-01-000	EA CAP-BUMPER, RUBBER - 4" X 4" - BLACK
3	083376-01-000	EA PLATE-SKID
4	107707-01-000	EA HITCH ASM-DRAWBAR, CLASS II
5	034513-01-000	EA PIN-HITCH, 3/16" WIRE
6	034512-01-000	EA PIN-LOCKING, DRAWBAR
	109738-01-01A	EA BRACKET-BUMPER MILL
	097744-02-000	EA HOUSING-TRAILER PIN, 48"
	097746-01-000	EA HOUSING CAP-TRAILER PIN
	097745-02-000	EA HOUSING-RECEPTACLE, TRAILER - 48" WIRE LENGTH
	113589-02-000	EA CONNECTOR-SOCKET, TRAILER - GENERAL 433601
	113589-01-000	EA CONNECTOR-PLUG, TRAILER - GENERAL 433501

CHASSIS GROUP (CONTINUED)

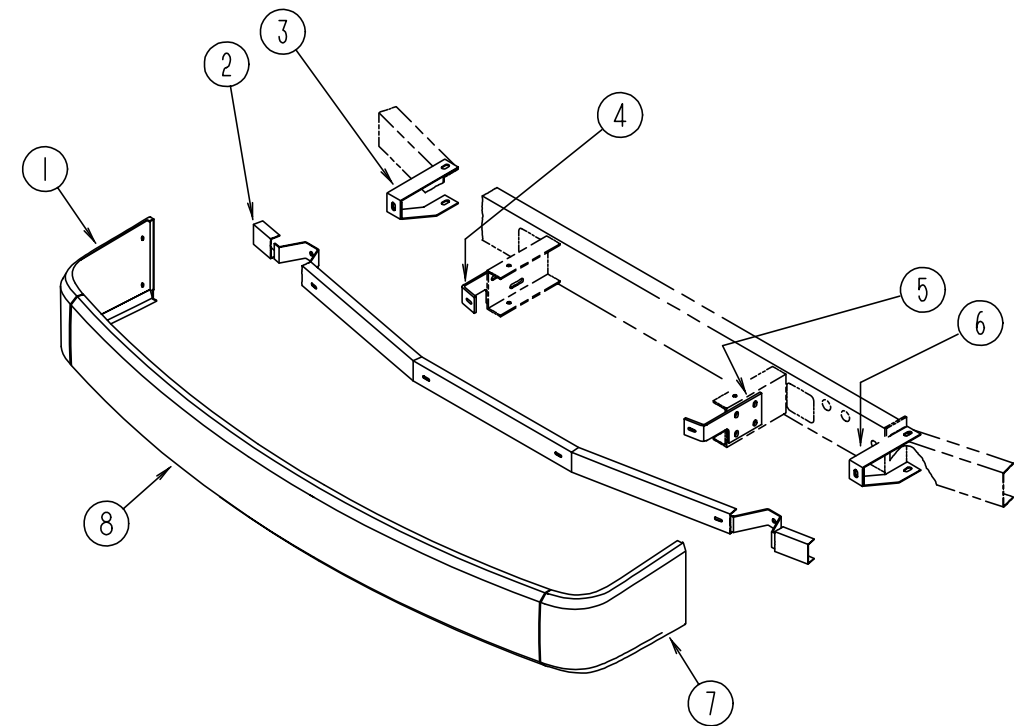

FRONT BUMPER

KEY	PART NUMBER	U/M DESCRIPTION
1	103625-01-01A	EA PANEL-FACIA, BUMPER FRONT RIGHT - OFF WHITE
1	103625-01-04A	EA PANEL-FACIA, BUMPER FRONT RIGHT - BRIGHT WHITE
2	103512-01-000	EA CHANNEL ASM-BUMPER
3	103497-01-000	EA BRACE-BUMPER, FRONT
4	086140-03-000	EA SUPPORT-FRONT BUMPER, PASSENGER SIDE - 9.1" X 4" - STEEL
5	086140-04-000	EA SUPPORT-FRONT BUMPER, DRIVER SIDE - 9.1" X 4" - STEEL
6	103611-01-000	EA BRACE-BUMPER, FRONT
7	103625-02-01A	EA PANEL-FACIA, BUMPER FRONT LEFT - OFF WHITE
7	103625-02-04A	EA PANEL-FACIA, BUMPER FRONT LEFT - BRIGHT WHITE
8	103626-01-01A	EA PANEL-FACIA, BUMPER FRONT - OFF WHITE
8	103626-01-04A	EA PANEL-FACIA, BUMPER FRONT - BRIGHT WHITE
8	103634-01-C05	EA BUMPER ASM-FRONT, W/RIGHT & LEFT FACIAS - OFF WHITE
8	103634-01-FB1	EA BUMPER ASM-FRONT, W/RIGHT & LEFT FACIAS - BRIGHT WHITE
	094362-02-000	EA CLIP-CHRISTMAS TREE, FLAT HEAD - .5" X .95"

CHASSIS GROUP (CONTINUED)**CHASSIS MISCELLANEOUS**

KEY	PART NUMBER	U/M DESCRIPTION
	076310-01-000	EA BAFFLE-RADIATOR - .12" X 15" X 62" - RUBBER
	087234-01-000	EA NUT-JACK - 1/4" X 20 THREADS - MOLLY - MOUNTS LICENSE PLATES
	080208-01-000	EA LUG WRENCH - 1.06 X 1.00
	080208-02-000	EA BAR-LEVERAGE - LUG WRENCH
	072877-01-000	EA INSULATION-SOUND BARRIER - 1.25" X 46" X 54"
	072878-01-000	EA INSULATION-SOUND BARRIER PAD - 29.25 "X 40.19"
	113875-01-000	EA HOSE-HUMP, 3" - TO TURBO CHARGER (DIESEL ONLY)
	093719-01-000	EA HOSE-OIL FILL - PREFORMED 90 DEGREE BEND (DIESEL ONLY)
	008042-01-000	FT TUBING-VINYL - .65" ID

CHASSIS GROUP (CONTINUED)**WHEELS, TIRES & WHEEL COVER**

KEY	PART NUMBER	U/M DESCRIPTION
	089359-03-000	EA WHEEL-STEEL - 16" X 6"K - 8 HOLE - PRIMED
	083425-07-000	EA TIRE-7.50XR16 LRD, MICHELIN XPS RIB
	051377-03-000	EA STEM-VALVE - TRO 600HP
	109443-05-000	EA WHEEL COVER - 4/SET - 16" - SS DICOR SHFM16
	083181-14-700	EA WHEEL-COVER - 1 ONLY - WHITE WC13
	111685-01-000	EA PLATE-SPARE TIRE

CHASSIS GROUP (CONTINUED)

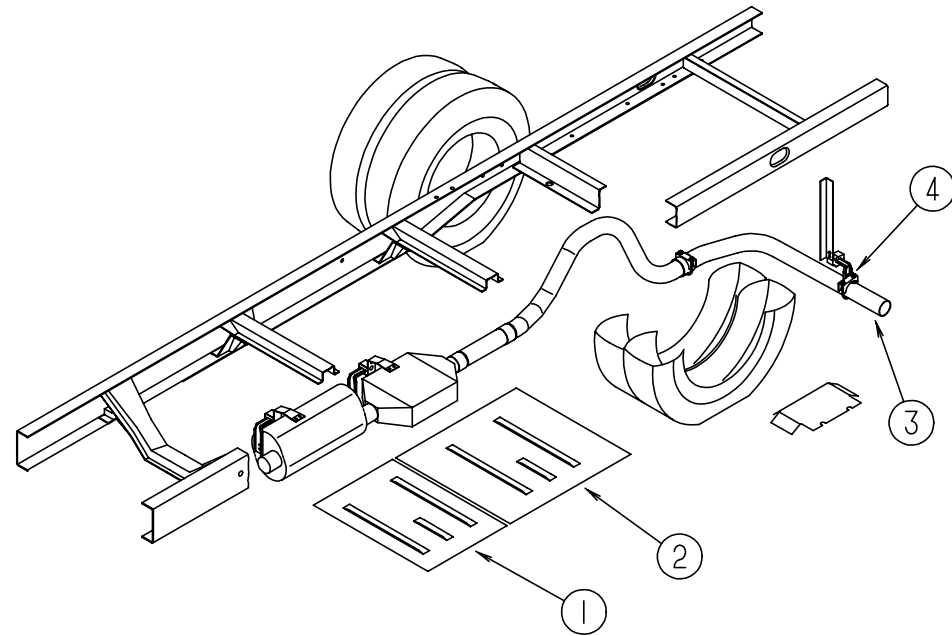

EXHAUST SYSTEM (GAS)

KEY	PART NUMBER	U/M DESCRIPTION
1	101544-05-000	EA SHIELD-HEAT - EXHAUST - 19.7" X 28.9" - STEEL
2	101544-02-000	EA SHIELD-HEAT - EXHAUST - 30" X 28.9" - STEEL
3	098762-05-000	EA PIPE-EXHAUST -STRAIGHT 3.0 IN
4	094918-01-000	EA CLAMP-EXHAUST - 3" - GUILLOTINE STYLE

CHASSIS GROUP (CONTINUED)

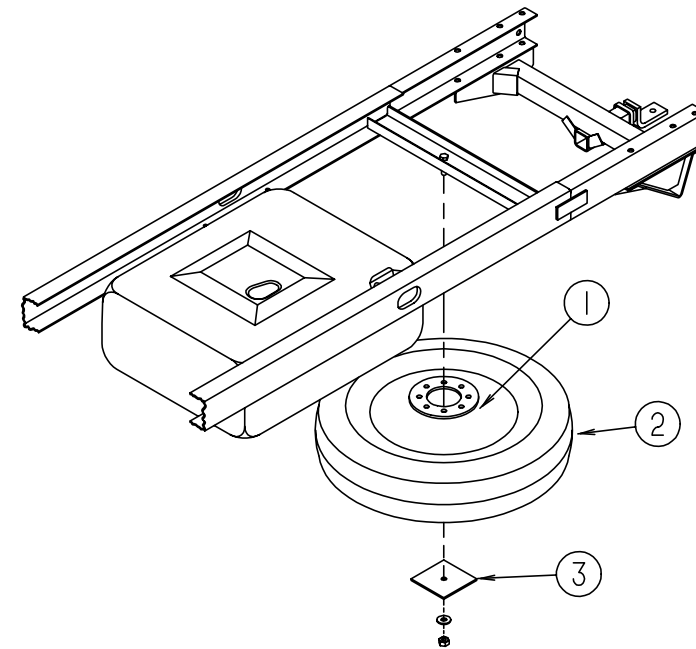

SPARE TIRE, LUG WRENCH & BAR

KEY	PART NUMBER	U/M DESCRIPTION
	M00080-69-000	EA TIRE & VALVE STEM
1	089359-03-000	EA WHEEL - STEEL, 16" X 6" K - 8 HOLE - PRIMED
2	083425-07-000	EA TIRE - 7.50 X R<16 LRD, MECHELIN XPS RIB
	051377-03-000	EA STEM - VALVE, TRO 600HP
3	111685-01-000	EA PLATE - SPARE TIRE
	080208-01-000	EA LUG WRENCH, 1.06 X 1.00
	080208-02-000	EA BAR - LEVERAGE, LUG WRENCH
4	094918-01-000	EA CLAMP-EXHAUST - 3" - GUILLOTINE STYLE

CHASSIS GROUP (CONTINUED)

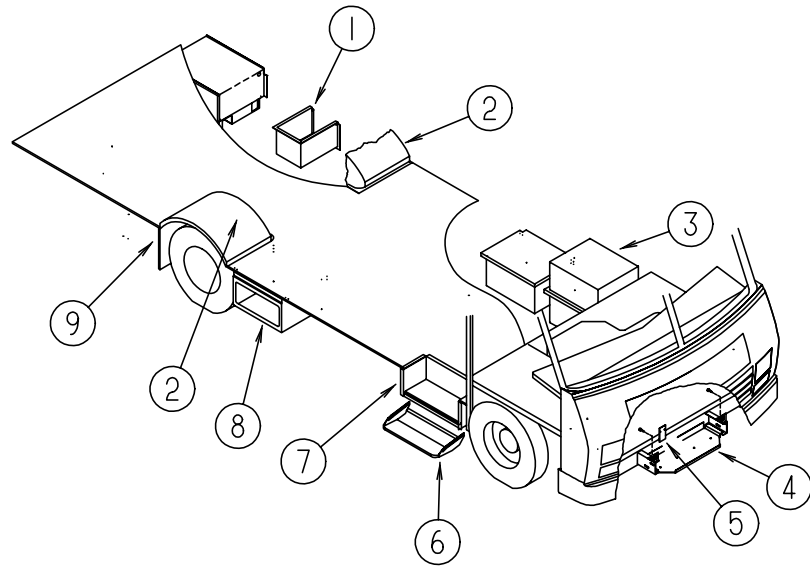

STORAGE COMPARTMENTS & WHEELWELLS

KEY	PART NUMBER	U/M	DESCRIPTION
1	102979-03-000	EA	BOX-POWER CORD
2	055080-01-000	EA	WHEELWELL-PLASTIC -REAR - BLACK - LEFT OR RIGHT
3	110184-01-000	EA	COMPARTMENT-STORAGE
4	065450-05-000	EA	TIEDOWN-BATTERY, 8.4" TUBE
5	109904-02-000	EA	ANGLE ASM-SOLENOID, 118 X 76.1MM W/WELD NUT - STEEL
6	077848-02-000	EA	STEP-PULLOUT - W/BRACKETS - BLACK
	091176-01-000	EA	SUPPORT-BASE-ENTRANCE STEP
7	076241-12-000	EA	BOX-SUPPORT, ENTRY DOOR STEP - 23.3" X 12.3" X 11.4" - ST
8	109814-02-000	EA	COMPARTMENT-STORAGE, 543 X 610MM - PLASTIC
9	020167-03-000	EA	DIRT GUARD-STEEL
	056746-01-000	EA	PLUG-CAP - 1" DIAMETER

CHASSIS GROUP (CONTINUED)

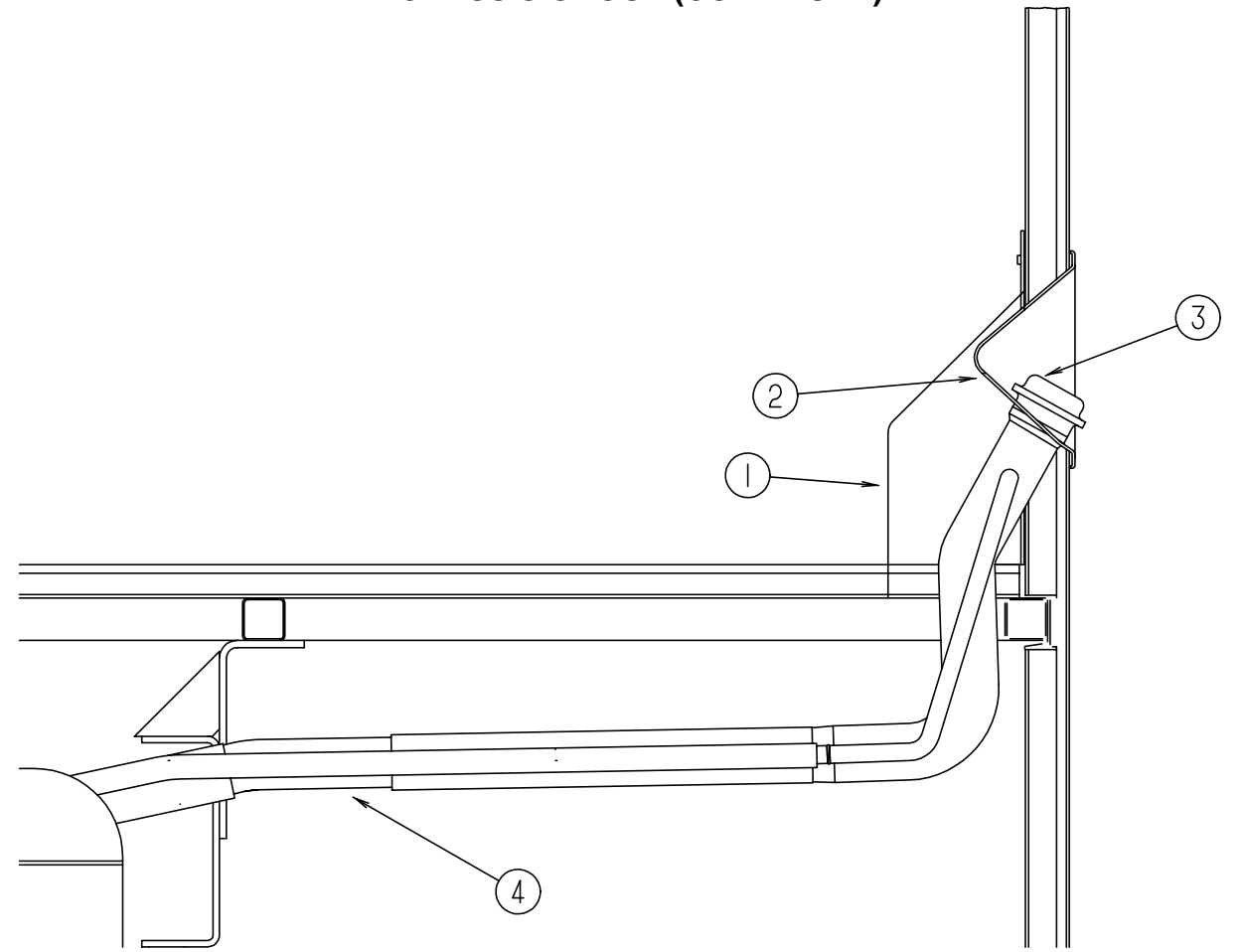

FUEL SYSTEM

KEY	PART NUMBER	U/M	DESCRIPTION
1	072447-04-000	EA	SHROUD-FUEL FILL, UPPER - PLASTIC
2	102951-01-02A	EA	SHROUD-FUEL FILL, OFF WHITE
2	102951-01-01A	EA	SHROUD-FUEL FILL-UNFINISHED
3	073220-02-000	EA	CAP-FILL, FUEL - NON LOCKING - GAS - GM 22525302
4	075228-01-000	EA	NECK-FUEL FILL, LOWER W/BEND - 9.3" LONG - GM14042359
	044317-01-000	FT	HOSE-FUEL, 3/8" ID
	007063-01-000	FT	HOSE-GAS 1/4"ID X 1/2"OD
	024142-01-000	EA	TEE-BARB, 3/16" - PLASTIC

CURTAIN & CUSHION GROUP

NOTICE

IN ORDER TO ASSIST OUR PARTS SALES DEPT. IN PROVIDING INTERIOR SOFTGOODS ITEMS, PLEASE INCLUDE THE SERIAL NUMBER AND THE COLOR CODE NUMBER FROM THE VEHICLE CERTIFICATION LABEL WHEN ORDERING. THIS LABEL IS LOCATED ON THE LEFT SIDEWALL AT THE END OF THE DASH (A-BODY), OR ON THE DRIVER'S DOOR LATCH PLATE (C-BODY).

AN EXAMPLE OF A COLOR CODE NUMBER IS B07, WHICH DESIGNATES AN OVERALL COLOR SCHEME OF A PARTICULAR UNIT. THE COLOR LISTED AFTER THE ITEM DESCRIPTION ON THE MICROFICHE, INDICATES THE OVERALL UNIT COLOR. ORDER THE ITEM YOU DESIRE ACCORDING TO UNIT COLOR CODE.

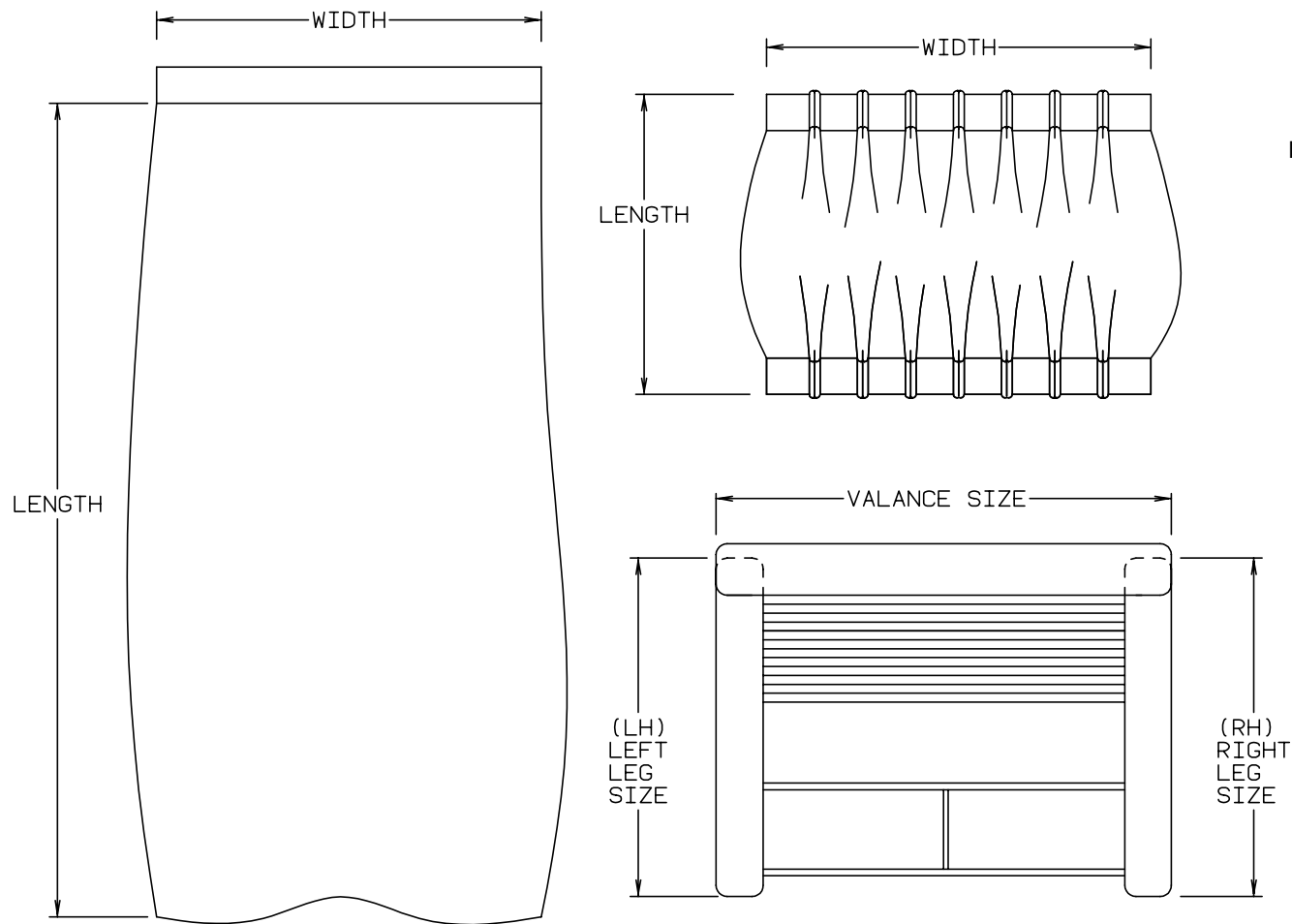

NOTE: USE THIS ILLUSTRATION WHEN DETERMINING LENGTH AND WIDTH MEASUREMENTS FOR CURTAINS. YOU WILL NOTE THE WIDTH MEASUREMENT IS TAKEN ON THE TOP OF THE CURTAIN WITH THE CURTAIN FULLY EXTENDED. THE LENGTH MEASUREMENT IS TAKEN FROM TOP TO BOTTOM. LEFT AND RIGHT WINDOW LEGS ARE DETERMINED WHEN FACING THE WINDOW.

CURTAIN & CUSHION GROUP (CONTINUED)

FABRIC TRIMS, SEAT BELTS & ASSIST HANDLE

KEY	PART NUMBER	U/M	DESCRIPTION
	007021-01-000	EA	BELT-SEAT, 2" X 90" - BLACK
	091990-04-01A	EA	BELT-SEAT, 2" X 72" - BLACK
	079349-04-E27	YD	WELT ASM-NARROW,ACCENT (FB1)
	079349-04-F16	YD	WELT ASM-NARROW,ACCENT (FC1)
	057759-01-000	EA	WASHER BRACKET-SEAT BELT, 4" DIAMETER
	069178-02-000	EA	BRACKET-MOUNTING, ASSIST HANDLE - L ANGLE - W/HOLES - ST
	070578-11-B18	EA	BUTTON SCREW-STUD, #30 VINYL
	000C16-07-16B	EA	BOLT-CARRIAGE, ASSIST HANDLE - 7/16" - 14 X 1" ZN
	000D20-07-00B	EA	NUT-ACORN,ASSIST HANDLE - 7/16" X 14 ZN
	053552-02-AA8	EA	HANDLE-ASSIST, INTERIOR - ENTRY DOOR - VINYL - OFF WHITE

FABRICS

KEY	PART NUMBER	U/M	DESCRIPTION
	087272-03-000	YD	DRAPERY LINING, 54" WIDE - IVORY
	075244-05-000	YD	VINYL-SHOWER GUARD, ROBIN BLUE (FB1)
	075244-07-000	YD	VINYL-SHOWER GUARD, EGGPLANT (FC1)
	103907-01-01A	YD	FABRIC-VINYL, 54" WIDE - OFF WHITE
	108446-B3-000	YD	FABRIC-UPHOLSTERY, MAIN - TERRITORY,GULF (FB1)
	108446-B8-000	YD	FABRIC-UPHOLSTERY, MAIN - TERRITORY,IVORY (FC1)
	108446-49-000	YD	FABRIC-UPHOLSTERY, PLAIN ACCENT ALBANY,695 TWILIG (FB1)
	108446-B4-000	YD	FABRIC-UPHOLSTERY, PLAIN ACCENT ALBANY,SMOKE (FC1)
	108446-B5-000	YD	FABRIC-UPHOLSTERY, PATTERN ACCENT - BRINKLEY,GULF (FB1)
	108446-B6-000	YD	FABRIC-UPHOLSTERY, PATTERN ACCENT - BRINKLEY,IVORY (FC1)
	105745-64-000	YD	FABRIC-BEDSPREAD, RADIANCE,SLATE (FB1)
	105745-62-000	YD	FABRIC-BEDSPREAD, RADIANCE,LILAC (FC1)
	105745-85-000	YD	FABRIC-BEDSPREAD,GALAXY,MAINLINE (FB1)
	105745-86-000	YD	FABRIC-BEDSPREAD, GALAXY,MAINLINE (FC1)

CURTAIN & CUSHION GROUP (CONTINUED)

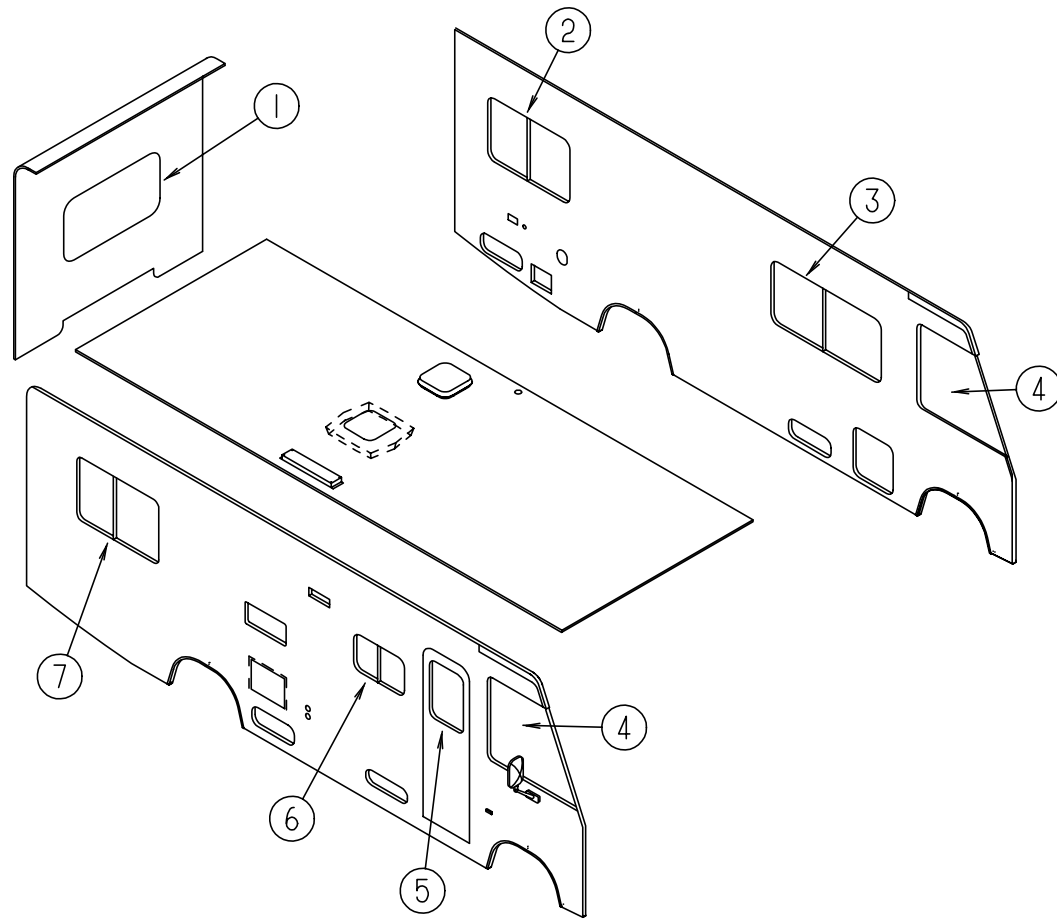

WINDOW TREATMENT

KEY	PART NUMBER	U/M	DESCRIPTION
1	104657-22-FB1	EA	VALANCE ASM-GEORGETOWN - 52" W/HEADER
1	104657-22-FC1	EA	VALANCE ASM-GEORGETOWN - 52" W/HEADER
1	P04657-22-FB1	EA	COVER-VALANCE - GEORGETOWN - 28" X 120" (EB1,EC1,EE1)
1	P04657-22-FC1	EA	COVER-VALANCE - GEORGETOWN - 28" X 120" (ED1)
1	101668-42-F15	EA	CURTAIN- 32" X 35" - TAPE TOP (FB1)
1	101668-42-F16	EA	CURTAIN- 32" X 35" - TAPE TOP (FC1)
1	084755-92-F15	EA	SHADE ASM-PULL-50.25" (FB1, FC1)
1	073260-25-F15	EA	TIEBACK ASM- 3" X 18" (FB1)
1	073260-25-F16	EA	TIEBACK ASM- 3" X 18" (FC1)
2	104657-03-F15	EA	VALANCE ASM-GEORGETOWN - 45" (FB1)
2	104657-03-F16	EA	VALANCE ASM-GEORGETOWN - 45" (FC1)
2	P04657-09-F15	EA	COVER-VALANCE - GEORGETOWN - 45" (FB1)
2	P04657-09-F16	EA	COVER-VALANCE - GEORGETOWN - 45" (FC1)
2	101668-44-F15	EA	CURTAIN- 29" X 35" - TAPE TOP (FB1)
2	101668-44-F16	EA	CURTAIN- 29" X 35" - TAPE TOP (FC1)
2	084755-89-FB1	EA	SHADE ASM-PULL - 43.25" (FB1, FC1)
2	073260-25-F15	EA	TIEBACK ASM- 3" X 18" (FB1)
2	073260-25-F16	EA	TIEBACK ASM- 3" X 18" (FC1)
3	105923-27-FB1	EA	VALANCE - RODEWAY W/1" INSERT 57.5"
3	105923-27-FC1	EA	VALANCE - RODEWAY W/1" INSERT 57.5"
3	076892-19-F15	EA	CURTAIN ASM - 31" X 15" - PLAIN HEM T&B (FB1)
3	076892-19-F16	EA	CURTAIN ASM - 31" X 15" - PLAIN HEM T&B (FC1)
3	076892-19-ED1	EA	CURTAIN ASM- 31" X 15" - PLAIN HEM T&B (ED1)
3	076892-19-DE1	EA	CURTAIN ASM- 31" X 15" - PLAIN HEM T&B (EE1)
3	084755-75-E91	EA	SHADE ASM-PULL-56.25 - W/O BRAID (FB1, FC1)
4	101668-31-EB1	EA	CURTAIN - TAPE TOP, 38" X 80" - RIGHT (FB1)
4	101668-31-FC1	EA	CURTAIN - TAPE TOP, 38" X 80" - RIGHT (FC1)
4	101668-30-EB1	EA	CURTAIN - TAPE TOP, 38" X 80" - LEFT (FB1)
4	101668-30-FC1	EA	CURTAIN - TAPE TOP, 38" X 80" - LEFT (FC1)
4	073260-42-FB1	EA	TIEBACK ASM-6" X 18"
4	073260-42-FC1	EA	TIEBACK ASM-6" X 18"
5	105923-34-FB1	EA	VALANCE ASM-RODEWAY W/1" EINSERT 29"
5	105923-34-FC1	EA	VALANCE ASM-RODEWAY W/1" EINSERT 29"
5	084755-95-FB1	EA	SHADE ASM-PULL - 25.5" NO TRIM
6	109041-20-01A	EA	BLIND-MINI, 31" X 18" DROP - PURE SILVER (FB1, FC1)
7	104657-01-F15	EA	VALANCE ASM - GEORGETOWN - 45" (FB1)
7	104657-01-F16	EA	VALANCE ASM - GEORGETOWN - 45" (FC1)
7	P04657-01-F15	EA	COVER-VALANCE - GEORGETOWN - 45" (FB1)
7	P04657-01-F16	EA	COVER-VALANCE - GEORGETOWN - 45" (FC1)
7	101668-42-F15	EA	CURTAIN - 32" X 35" - TAPE TOP (FB1)
7	101668-42-F16	EA	CURTAIN - 32" X 35" - TAPE TOP (FC1)
7	084755-89-FB1	EA	SHADE ASM-PULL-43.25" (FB1, FC1)
7	073260-25-F15	EA	TIEBACK ASM- 3" X 18" (FB1)
7	073260-25-F16	EA	TIEBACK ASM- 3" X 18" (FC1)
	084481-25-D12	EA	CURTAIN ASM-SHOWER - 67" X 38" (FB1)
	084481-25-D36	EA	CURTAIN ASM-SHOWER - 67" X 38" (FC1)
	073260-54-C30	EA	TIEBACK ASM - 3" X 16" (SHOWER) (FB1)
	073260-54-D36	EA	TIEBACK ASM - 3" X 16" (SHOWER) (FC1)
	101668-49-FB1	EA	CURTAIN - 61" X 48" - ROOM DIVIDER - LINED
	101668-49-FC1	EA	CURTAIN - 61" X 48" - ROOM DIVIDER - LINED
	073260-63-FB1	EA	TIEBACK ASM - 4" X 15" (EB1)(ROOM DIVIDER)
	073260-63-FC1	EA	TIEBACK ASM - 4" X 15" (EC1)(ROOM DIVIDER)
	073260-55-ED1	EA	TIEBACK ASM - 4" X 15" (ED1)(ROOM DIVIDER)
	073260-55-EE1	EA	TIEBACK ASM - 4" X 15" (EE1)(ROOM DIVIDER)

CURTAIN & CUSHION GROUP (CONTINUED)

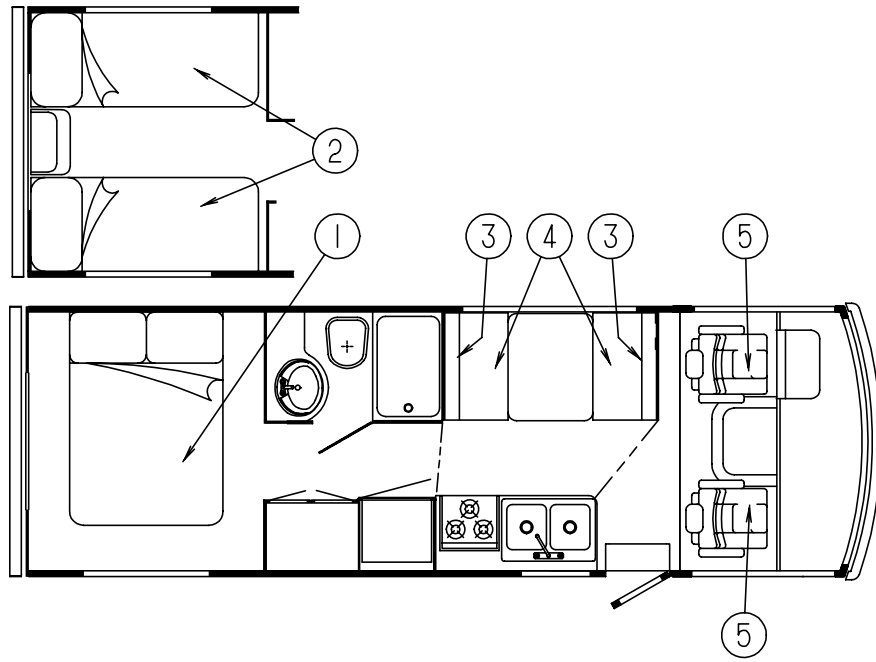

DOUBLE BED

KEY	PART NUMBER	U/M DESCRIPTION
1	101123-17-EB1	EA MATTRESS COMPLETE-FOAM - 54" X 74" X 5" (FB1, FC1)
	P01123-17-000	EA COVER-MATTRESS - 54" X 74" X 5" (FB1, FC1)
1	102410-13-FB1	EA BEDSPREAD - THROW W/4" RUFFLE., 54 X 74 X 5
1	102410-13-FC1	EA BEDSPREAD - THROW W/4" RUFFLE., 54 X 74 X 5
1	102161-25-F15	EA SHAM - W/4" RUFFLE (FB1)
1	102161-25-F16	EA SHAM - W/4" RUFFLE (FC1)

TWIN BED CUSHIONS

KEY	PART NUMBER	U/M DESCRIPTION
2	101123-18-000	EA MATTRESS-COMPLETE-FOAM 32" X 79" X 5" (FB1, FC1)
	P01123-18-000	EA COVER-MATTRESS - 32" X 74" X 5" (FB1, FC1)
2	085365-28-FB1	EA BEDSPREAD - 33" X 80" - W/ROUNDED CORNER (FB1)
2	085365-28-FC1	EA BEDSPREAD - 33" X 80" - W/ROUNDED CORNER (FC1)

DINETTE CUSHIONS

KEY	PART NUMBER	U/M DESCRIPTION
3	116134-01-FB1	EA CUSHION - BACKREST - 13" X 37.5" X 5" (FB1)
3	116134-01-FC1	EA CUSHION - BACKREST - 13" X 37.5" X 5" (FC1)
	P16134-01-FB1	EA COVER - BACKREST CUSHION - 13" X 37.5" X 5" (FB1)
	P16134-01-FC1	EA COVER - BACKREST CUSHION - 13" X 37.5" X 5" (FC1)
4	088927-87-F15	EA CUSHION - SEAT, 23" X 37.5" X 5" (FB1)
4	088927-87-F16	EA CUSHION - SEAT, 23" X 37.5" X 5" (FC1)
	M88927-87-F15	EA COVER - CUSHION - SEAT, 23" X 37.5" X 5" (FB1)
	M88927-87-F16	EA COVER - CUSHION - SEAT, 23" X 37.5" X 5" (FC1)
	078155-01-000	EA STRAP-SNAP - BACKREST CUSHION

BUCKET SEAT

KEY	PART NUMBER	U/M DESCRIPTION
5	110148-04-FB1	EA SEAT - ECONOMIZER II - ECONOMIZER ARM
5	110148-04-FC1	EA SEAT - ECONOMIZER II - ECONOMIZER ARM

FRONT BUNK CUSHIONS

KEY	PART NUMBER	U/M DESCRIPTION
	079145-10-000	EA CUSHION-BUNK - 25" X 80" X 2.5"
	M79145-10-000	EA COVER-BUNK - 25" X 80" X 2.5"

CURTAIN & CUSHION GROUP (CONTINUED)

DRIVER & PASSENGER BUCKET SEATS

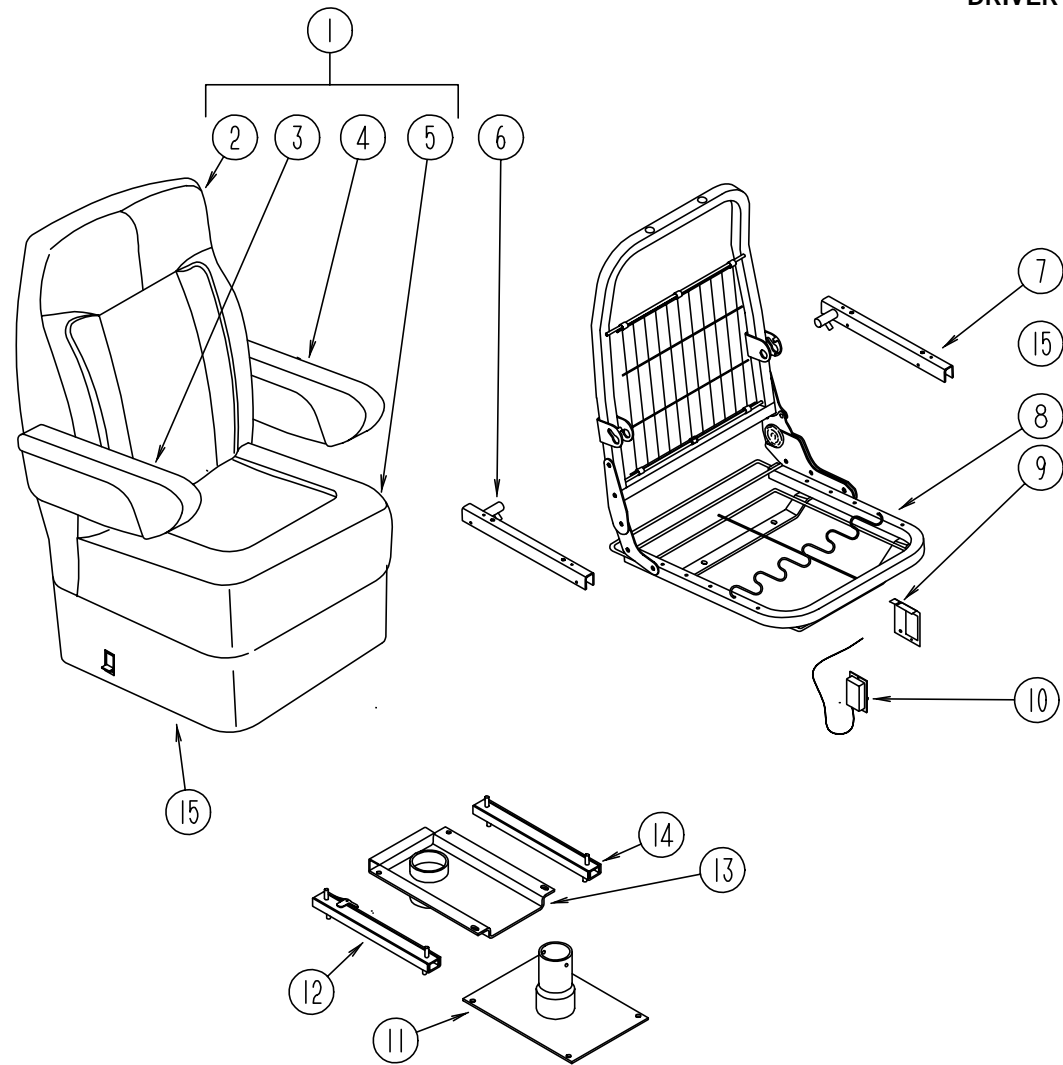

KEY	PART NUMBER	U/M	DESCRIPTION
1	110148-04-FB1	EA	SEAT-ECONOMIZER II - -ECONOMIZER ARM (FB1)
1	110148-04-FC1	EA	SEAT-ECONOMIZER II - -ECONOMIZER ARM (FC1)
2	M05962-17-FB1	EA	COVER-ECONOMIZER - BACK (FB1)
2	M05962-17-FC1	EA	COVER-ECONOMIZER - BACK (FC1)
3	115520-01-FB1	EA	ARMREST-RIGHT - FAN (FB1)
3	115520-01-FC1	EA	ARMREST-RIGHT - FAN (FC1)
	P15520-01-FB1	EA	COVER-ARMREST-RIGHT - FAN (FB1)
	P15520-01-FC1	EA	COVER-ARMREST-RIGHT - FAN (FC1)
4	115520-02-FB1	EA	ARMREST-LEFT - FAN (FB1)
4	115520-02-FC1	EA	ARMREST-LEFT - FAN (FC1)
	P15520-02-FB1	EA	COVER-ARMREST-LEFT - FAN (FB1)
	P15520-02-FC1	EA	COVER-ARMREST-LEFT - FAN (FC1)
5	M05962-18-FB1	EA	COVER-ECONOMIZER II - SEAT (FB1)
5	M05962-18-FC1	EA	COVER-ECONOMIZER II - SEAT (FC1)
6	081268-01-000	EA	ROD & CHANNEL-ARMREST - RIGHT - METAL
7	081361-01-000	EA	ROD-ARMREST - METAL - RIGHT OR LEFT HAND
8	M80906-11-000	EA	FRAME ASM-SEAT & BACK & SPRING
9	097683-03-000	EA	BRACKET-REMOTE - SIDE MOUNT - SINGLE
	080730-08-000	EA	HANDLE-30179907 KEIPER
	080730-09-000	EA	SHEILD-FLEXSTEEL
	080730-11-000	EA	SHIELD-RUBBER BOOT FLEXSTEEL
10	089368-04-000	EA	CABLE-SWIVEL/SLIDE, W/SWITCH
11	107921-01-000	EA	PEDESTAL ASM-SEAT 9-3/4" - FLEXSTEEL 3060 MSPD
12	069246-05-000	EA	ADJUSTER-BUCKET SEAT W/ REMOTE - FORWARD AND BACK
13	107921-05-000	EA	TOP PLATE - FLEXSTEEL
	107921-06-000	EA	BEARING KIT - FLEXSTEEL
14	069246-02-000	EA	ADJUSTER-SEAT/CHAIR - W/O LOCK - FORWARD & BACK
	007221-01-000	EA	SPACER-SEAT - ADJUSTER
15	071126-41-F15	EA	SKIRT ASM-SINGLE - 7" - W/SLOT (FB1)
15	071126-41-F16	EA	SKIRT ASM-SINGLE - 7" - W/SLOT (FC1)

CURTAIN & CUSHION GROUP (CONTINUED)

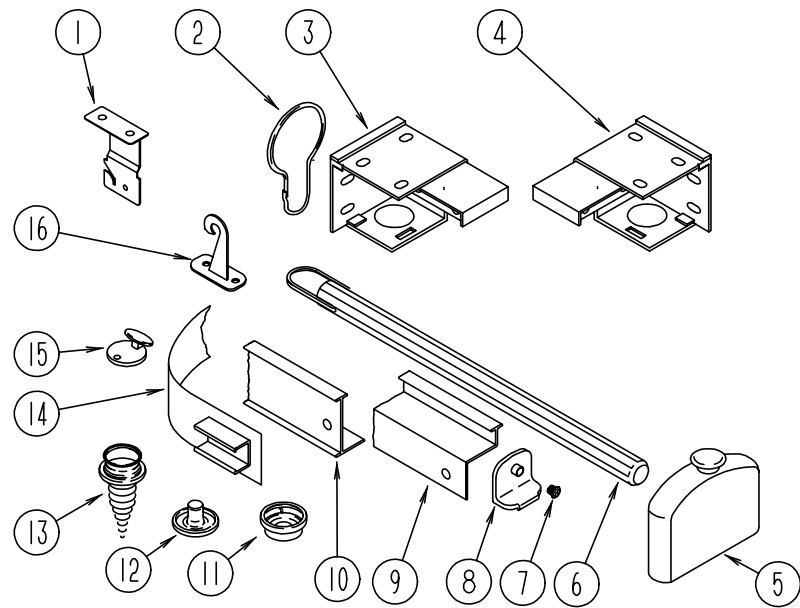

CURTAIN HARDWARE

KEY	PART NUMBER	U/M	DESCRIPTION
1	084434-01-000	EA	BRACKET-MOUNTING, ROLLER SHADE - 1 3/8"
2	009136-02-000	EA	HANGER-RING, PIN TYPE - CURTAIN - BRASS
3	083170-02-000	EA	BRACKET-BLIND, LEFT SIDE
4	083170-01-000	EA	BRACKET-BLIND, RIGHT SIDE
5	093475-01-701	EA	END CAP-BLIND, W/STUD
6	093475-01-700	EA	WAND-BLIND, W/METAL CLIP - 8" LONG
7	106544-01-001	EA	SCREW-BRASS, SHADE
8	106544-01-000	EA	PULL-SHADE, BRASS
	084432-06-000	FT	SLAT-ROLLER SHADE, PLASTIC
	096843-01-000	EA	SPRING-REWIND, ROLLER SHADE
9	105324-02-01A	EA	TRACK-CURTAIN, WRAPAROUND - PASSENGER SIDE - OFF WHITE
9	105324-03-01A	EA	TRACK-CURTAIN, WRAPAROUND - DRIVER SIDE - OFF WHITE
9	105450-02-01A	EA	TRACK-CURTAIN, 48" LONG - ALUMINUM - OFF WHITE
9	105450-07-01A	EA	TRACK-CURTAIN, 41.3" LONG - ALUMINUM - OFF WHITE
9	105450-08-01A	EA	TRACK-CURTAIN, 38" LONG - ALUMINUM - OFF WHITE
9	105450-09-01A	EA	TRACK-CURTAIN, 55.5" LONG - ALUMINUM - OFF WHITE
10	009700-04-002	EA	TRACK-CURTAIN, L-SHAPED - 195.2" LONG - OFF WHITE
10	084621-02-000	EA	TRACK-SHOWER, CURVED - OFF WHITE
11	029156-01-000	EA	SOCKET-SNAP, 9/16" O.D.
12	029155-01-000	EA	CAP-SNAP, 5/32" O.D. OF PIN
13	029130-01-000	EA	SCREW-SNAP SOCKET, 8 PH X 5/8"
14	101031-01-000	YD	TAPE-GLIDE, CURTAIN - 4.25" SPACING
15	102555-01-000	EA	CLEAT-CORD, BLIND - OFF WHITE
16	109441-01-000	EA	HOLD DOWN-BLIND, HOOK
	056003-01-000	EA	BRACKET-DRAPERY RETAINING, METAL - RIGHT
	056003-02-000	EA	BRACKET-DRAPERY RETAINING, METAL - LEFT
	046867-01-000	EA	GROMMET-BRASS, 7/16" ID X 1" OD
	068716-01-001	EA	BRACE - 90 DEGREE, L-ANGLE - 192" - EXTRUDED ALUMINUM
	048394-02-000	YD	VELCRO TAPE-HOOK, ADHESIVE BACK - .75" WIDE - BEIGE
	088792-02-000	YD	VELCRO TAPE-LOOP, ADHESIVE BACKED - .75" WIDE - BEIGE
	088792-01-000	YD	VELCRO-HOOK, .75" WIDE - BEIGE
	086276-01-000	EA	TAPE-DOUBLE SIDED, 1/2"

DINETTE GROUP

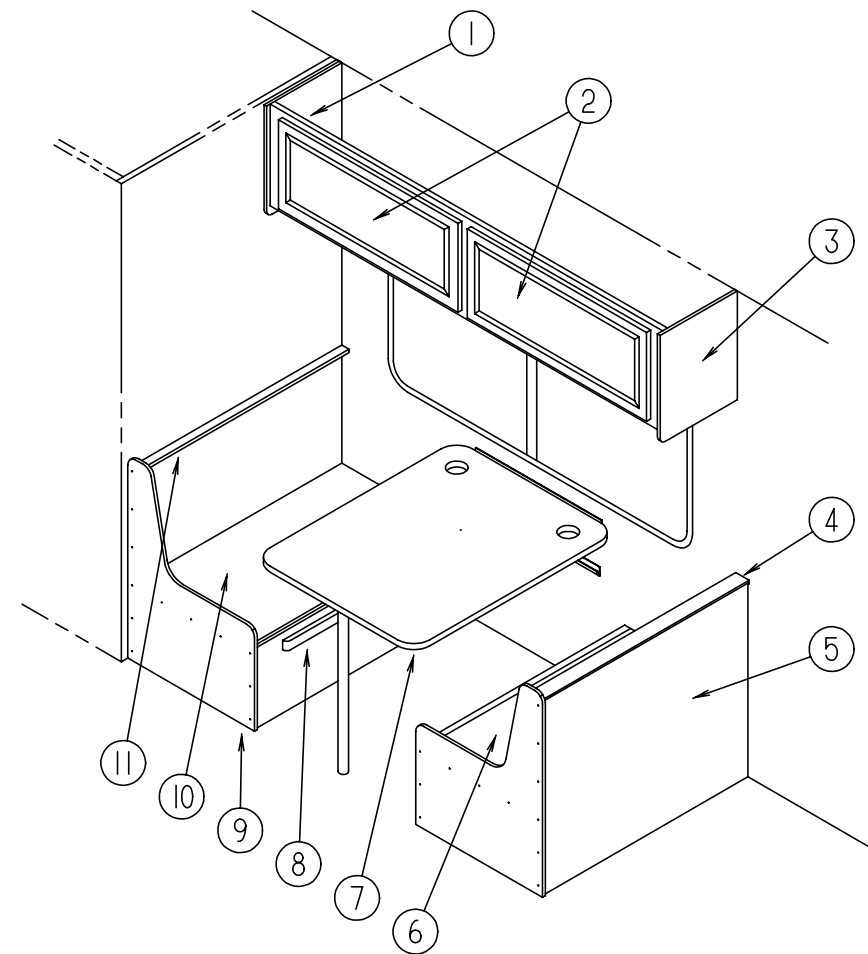

DINETTE CABINETRY

KEY	PART NUMBER	U/M	DESCRIPTION
1	109920-02-FB1	EA	CABINET ASM-OVERHEAD - DINETTE
2	110140-65-F15	EA	DOOR ASM-MITERED - VINYL WRAP
3	109908-03-EB1	EA	CAP ASM-END - OVERHEAD
4	109995-01-F15	EA	PAD ASM-DINETTE(FB1)
4	109995-01-F16	EA	PAD ASM-DINETTE(FC1)
5	M04175-50-EB1	EA	CABINET-SEATBASE - RIGHT
	M04174-50-FB1	EA	CABINET-SEATBACK - RIGHT
6	081518-13-EB1	EA	SEAT-DINETTE
7	M02115-09-F15	EA	PANEL KIT-DINETTE TABLE
8	081295-01-AA8	EA	SUPPORT-BED - DINETTE - 712 LG
9	M04175-51-EB1	EA	CABINET-SEATBASE - LEFT
10	081518-14-EB1	EA	SEAT-DINETTE
11	109995-02-FB1	EA	PAD ASM-DINETTE(FB1)
11	109995-02-FC1	EA	PAD ASM-DINETTE(FC1)

DINETTE GROUP (CONTINUED)

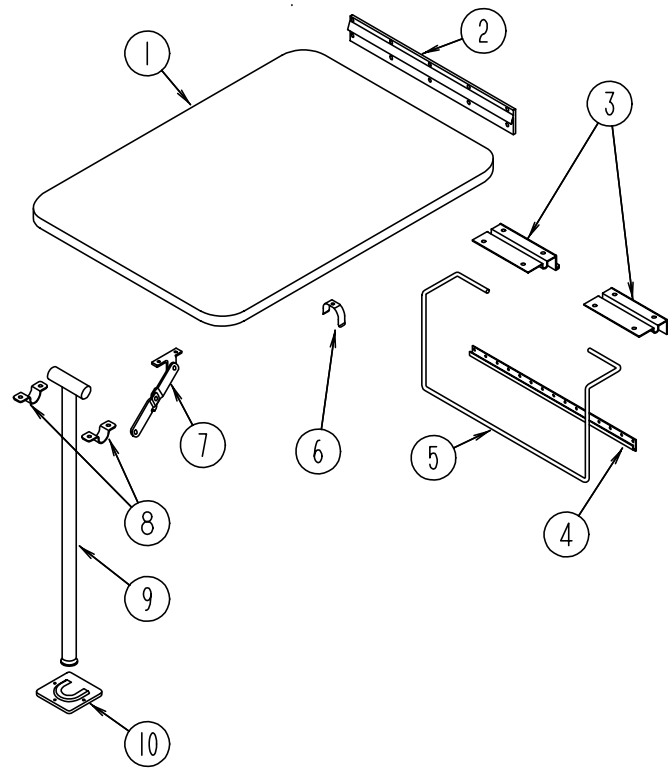

DINETTE TABLE

KEY	PART NUMBER	U/M	DESCRIPTION
1	M02115-09-F15	EA	TABLE-DINETTE, W/O HARDWARE
2	053200-12-000	EA	SUPPORT-TABLE, 23.50" - OFF WHITE
3	088410-02-000	EA	HANGER-TABLE, OFF WHITE
4	024281-14-000	EA	BRACKET-TABLE LIFT, 22.12" - OFF WHITE
5	024275-12-000	EA	ROD-TABLE LIFT, OFF WHITE
6	024283-01-000	EA	CLIP-LEG, 1" - 1.125" OD - BLACK
7	024282-01-000	EA	BRACE-TABLE LEG, HINGED
8	064050-05-000	EA	HINGE-TABLE LEG, OFF WHITE
9	024276-23-000	EA	LEG ASM-TABLE OFF WHITE
10	049493-12-000	EA	CATCH-TABLE LEG, OFF WHITE
10	049493-11-700	EA	CATCH-LEG, FLOOR MOUNTED - 2.5" X 2.7" - METAL - E-COAT

DRIVERS COMPARTMENT GROUP

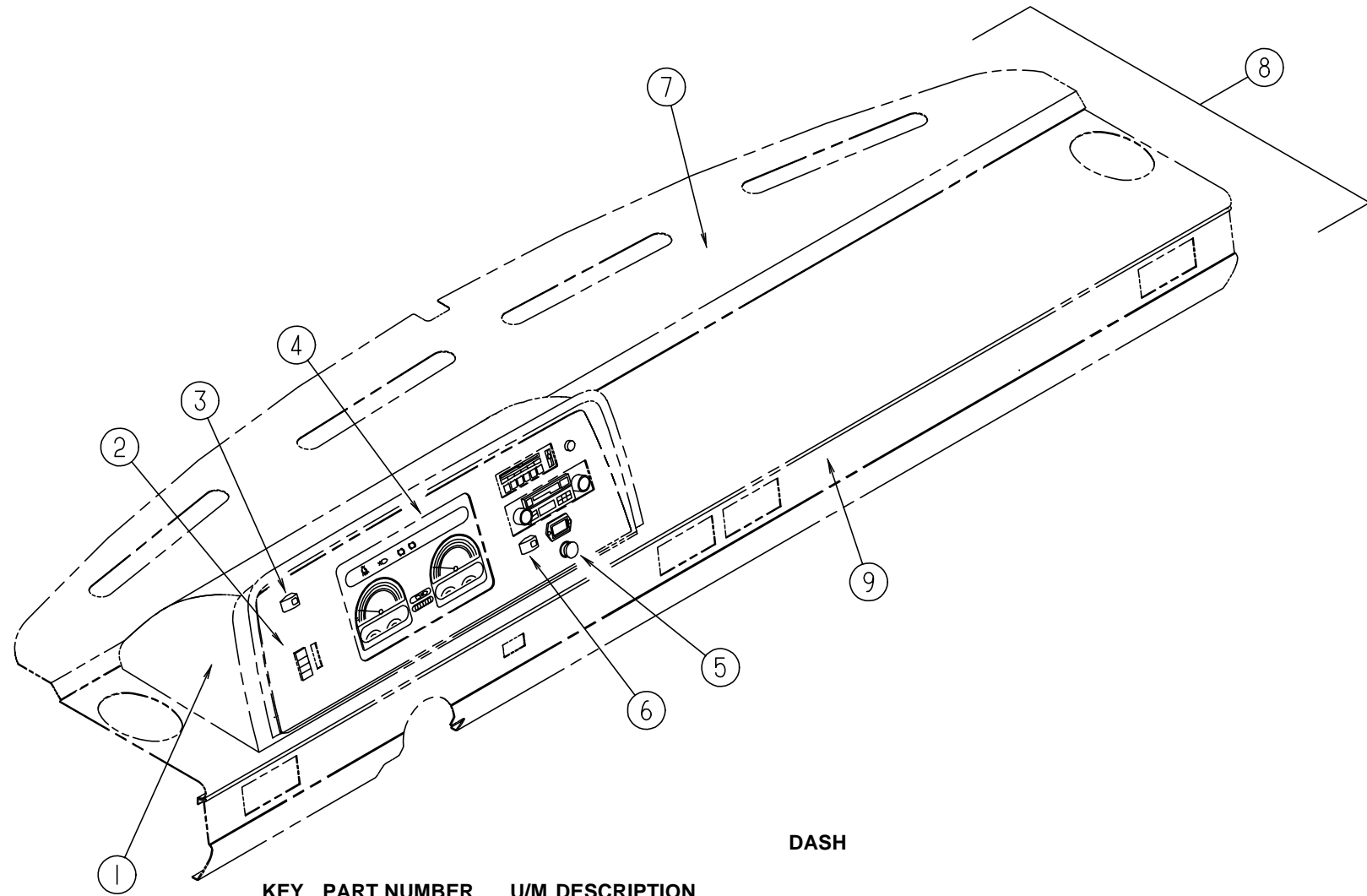

DASH

KEY	PART NUMBER	U/M	DESCRIPTION
	M05946-11-EB1	EA	DASH POD ASM, COMPLETE W/ALL ELECTRIC COMPONENTS - CHEVY
1	110066-01-01A	EA	POD-INSTRUMENT PANEL
	079382-01-000	EA	SCREW-SOCKET, 8-18 X 1" - BLACK
	103603-01-000	EA	BULB-12V, # 74 0.12A WEDGE
	077539-01-000	EA	BRACKET-MOUNTING, DASH PANEL - L/SHAPED - 2.5" X 1" X 1.5"
2	109829-02-01A	EA	BEZEL-INSTRUMENT PANEL, BLACK
2	110073-01-01A	EA	APPLIQUE-BEZEL, INSTRUMENT PANEL - BLACK VELVET
	100138-01-000	EA	MODULE-DAYTIME RUNNING LIGHT
	077031-01-000	EA	FILM-BLACK, 1" X 1.75"
	077031-03-000	EA	FILM-WHITE, .75" X 1.00"
	105615-01-000	FT	FILM-PROTECTIVE, CLEAR - 34" WIDE
3	108357-09-000	EA	SWITCH-ROCKER, SPDT ON/NONE/MOM - CARLING V5D1000B-0
3	108356-02-01A	EA	COVER-SWITCH W/DIMPLES, CARLING VVAZC00 BLA
4	094796-07-000	EA	CLUSTER-INSTRUMENT PANEL, KILOMETERS - GAS - GM #16201075 (CSA)
5	089294-01-000	EA	LIGHTER ASM-CIGARETTE, CASCO C213275
6	108357-10-000	EA	SWITCH-ROCKER, SPDT MOM/OFF/MOM - CARLING V8D1160B-0
6	108356-04-01A	EA	COVER-SWITCH W/DIMPLES & LENS, CARLING VVAGC00
	106569-02-01A	EA	VINYL-LAMINATE MADRID, OFF WHITE - 1/4" X 16" X 96"
7	105927-02-000	EA	PANEL ASM-DASH, TOP - W/STUD - STEEL
8	P03817-06-000	EA	DASH ASM, CHEVY - W/O VINYL & INSTRUMENT POD - STEEL
9	103812-01-01A	EA	TRIM-DASH, LOWER - GM - OFF WHITE
	103812-01-03A	EA	TRIM-DASH, LOWER - GM - MILL

DRIVERS COMPARTMENT GROUP (CONTINUED)

DRIVERS COMPARTMENT

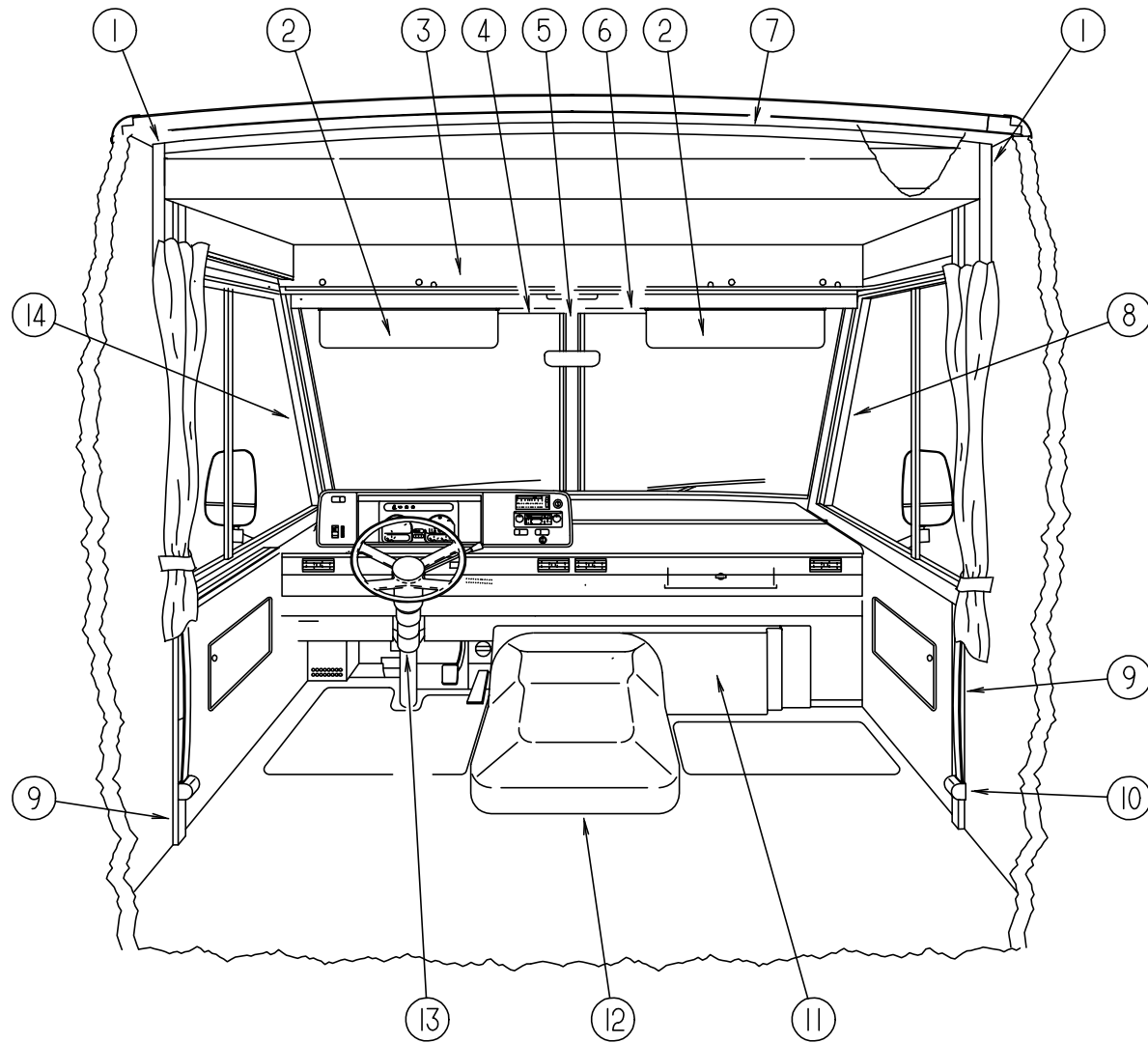

KEY	PART NUMBER	U/M	DESCRIPTION
1	P12274-01-01A	EA	COVER-ROLL BAR, W/BUNK OFF WHITE
2	082286-18-F04	EA	SUNVISOR ASM, W/O POCKET
	007211-01-000	EA	HINGE-SUNVISOR, 25.5" X 1.5" - METAL
	074012-01-000	EA	CLIP-SUNVISOR, SQUARE - PINCH ON
	102377-01-000	EA	BRACKET-SUNVISOR, 1 PIECE - STEEL
3	109795-01-FB1	EA	PANEL-HEADLINER, VERTICAL SECTION
	078811-07-FB1	EA	PANEL-HEADER, HORIZONTAL SECTION - W/LIGHT & SPEAKER CUTOUTS
4	078579-08-000	EA	TRIM-WINDSHIELD, UPPER - INNER - DRIVER - OFF WHITE
5	079765-07-000	EA	TRIM-WINDSHIELD, CENTER - PRECUT ENDS - OFF WHITE
5	079765-09-000	EA	TRIM-WINDSHIELD, CENTER - UNCUT - OFF WHITE
6	078579-07-000	EA	TRIM-WINDSHIELD, UPPER - INNER - PASSENGER - OFF WHITE
7	024700-51-000	EA	COVER-ROLL BAR, OFF WHITE - 88.00"
8	103931-01-01A	EA	COVER-INTERIOR, A-PILLAR - RIGHT - OFF WHITE
9	024700-52-000	EA	COVER-ROLL BAR, OFF WHITE - 41.50"
	024700-49-000	EA	COVER-ROLL BAR, OFF WHITE 57.00 INCHES
	024700-50-000	EA	COVER-ROLL BAR, OFF WHITE 8.00 INCHES
	110056-01-01A	EA	COVER-ROLL BAR 90 DEGREE OFF WHITE
10	056271-02-000	EA	BELT-SEAT, 2" X 72" - BLACK
	057759-01-000	EA	WASHER BRACKET-SEAT BELT, 4" DIAMETER
11	095757-03-F03	EA	COVER ASM-HEATER (FB1)
11	095757-03-FC1	EA	COVER ASM-HEATER (FC1)
12	097552-01-000	EA	COVER-MOTOR, W/O CARPET
	039623-01-000	FT	SEAL-MOTOR COVER, RUBBER BULB TYPE - BLACK
	113828-02-01A	EA	TRIM-MOTOR COVER, ALUMINUM
	002754-01-001	EA	ANGLE-EXTRUDED, .75" X .75" X 18' - MILL ALUMINUM
	075564-01-000	EA	BRACKET-MOUNTING, MOTOR COVER
13	103498-06-000	EA	BOOT-COLUMN
14	103931-02-01A	EA	COVER-INTERIOR, A-PILLAR -LEFT - OFF WHITE

DRIVERS COMPARTMENT GROUP (CONTINUED)**OVERHEAD BUNK**

KEY	PART NUMBER	U/M	DESCRIPTION
	076760-04-000	EA	BUNK HARDWARE-OVERHEAD KWIKEE #901401
	076760-02-700	EA	SPRING-GAS, BUNK HARDWARE
	110007-01-DB1	EA	BED ASM-BUNK,FRONT
	099717-03-000	EA	TIEDOWN ASM-TV

ELECTRICAL GROUP**INTERIOR LIGHTS**

KEY	PART NUMBER	U/M	DESCRIPTION
	098024-01-01A	EA	LIGHT-DOME - 1 BULB - US - IVORY
	008218-01-000	EA	BULB-DOME LIGHT - 12V - NUMBER 1141
	098024-01-700	EA	LENS-DOME LIGHT
	098024-03-01A	EA	LIGHT-DOME - 2 BULB - IVORY
	008218-01-000	EA	BULB-DOME LIGHT - 12V - NUMBER 1141
	098024-01-700	EA	LENS-DOME LIGHT

FUSES & CIRCUIT BREAKERS

KEY	PART NUMBER	U/M	DESCRIPTION
	062901-02-000	EA	FUSE - 5 AMPS - AUTOMOTIVE
	062901-05-000	EA	FUSE - 15 AMPS - AUTOMOTIVE
	062901-08-000	EA	FUSE - 30 AMPS - AUTOMOTIVE
	099027-01-000	FT	FUSE LINK - 12 AWG - BELDEN 12 AWG
	083209-01-000	EA	CIRCUIT BREAKER - 15 AMP - 120V - BW G-15 - CANADIAN
	083209-02-000	EA	CIRCUIT BREAKER - 15/15AMP - 120V - BW H-15/15
	083209-04-000	EA	CIRCUIT BREAKER - 30A - 120V - BW L-30
	083209-05-000	EA	CIRCUIT BREAKER - 20A - 120V - BW J-20
	083209-06-000	EA	CIRCUIT BREAKER - 30/15 AMP - 120V - BW D-30/15
	097611-01-000	EA	CIRCUIT BREAKER - 6AMP - ATC - BLACK
	062037-01-000	EA	HOUSING-AUTO FUSE - NATURAL
	062037-02-000	EA	HOUSING-AUTO FUSE - GREEN
	062037-03-000	EA	HOUSING-AUTO FUSE - BLACK
	062037-04-000	EA	HOUSING-AUTO FUSE - BLUE
	062037-05-000	EA	HOUSING-AUTO FUSE - GRAY
	062037-06-000	EA	HOUSING-AUTO FUSE - BROWN
	106655-02-000	EA	TERMINAL-FUSE BLOCK - 10-12AWG - PACKARD 12020400

CONDUIT

KEY	PART NUMBER	U/M	DESCRIPTION
	041953-01-000	FT	CONDUIT-CONVOLUTE - SLIT - .5" ID
	041953-05-000	FT	CONDUIT-CONVOLUTE - SOLID - .62" ID
	041953-06-000	FT	CONDUIT-CONVOLUTE - SLIT - .375" ID
	041953-07-000	FT	CONDUIT-CONVOLUTE - SLIT - .25" ID
	041953-09-000	FT	CONDUIT-CONVOLUTE - SLIT - .50" ID

SWITCHES & RECEPTACLES

KEY	PART NUMBER	U/M	DESCRIPTION
	108355-01-000	EA	HOUSING-SWITCH - CARLING VCH
	108356-02-01A	EA	COVER-SWITCH W/DIMPLES - CARLING VVAZC00 BLA
	108356-04-01A	EA	COVER-SWITCH W/DIMPLES & LENS - CARLING VVAGC00
	108357-09-000	EA	SWITCH-ROCKER - SPDT ON/NONE/MOM - CARLING V5D1000B-0
	108357-10-000	EA	SWITCH-ROCKER - SPDT MOM/OFF/MOM - CARLING V8D1160B-0
	096241-03-000	EA	SWITCH-BLANK
	007940-01-000	EA	RECEPTACLE-SLIDE - 16 TO 12 AWG - FEMALE END
	058707-01-000	EA	RECEPTACLE-ELECTRIC - SINGLE - BROWN
	058708-01-000	EA	RECEPTACLE-ELECTRIC - DOUBLE - BROWN
	058708-02-000	EA	RECEPTACLE-ELECTRIC - DOUBLE - IVORY
	084076-02-000	EA	RECEPTACLE-GFI - 15A - 125V - BROWN
	024924-02-000	EA	RECEPTACLE-POWER CORD - W/PARTIAL PLATE
	075723-01-000	EA	SPACER-SWITCH - W/O HOLE - .2" X .9" X 2" - METAL - OFF WHITE
	102568-01-E90	EA	SPACER-RECEPTACLE - SIDEWALL

ELECTRICAL GROUP (CONTINUED)

POWER CORD, CONVERTER & WIRE ASSEMBLIES

KEY	PART NUMBER	U/M	DESCRIPTION
	109677-01-000	EA	LOAD CENTER - 120V - 40A - WESCO TT120FLGNM
	083208-01-000	EA	CONVERTER-POWER - 32A - 120V/12V - BW 6332
	008052-01-000	EA	CORD-POWER - 10/3 - 30 AMP - 25' - CANADIAN
	008054-01-000	EA	CORD-POWER - 10/3 - 30 AMP - 25'
	097618-01-000	EA	WIRE ASM-MONITOR PANEL - W/4 WIRES & BLACK RESISTOR - LVS
	096449-01-000	EA	WIRE ASM-WATER TANK TO MONITOR PANEL

ELECTRICAL BOXES & COVERS

KEY	PART NUMBER	U/M	DESCRIPTION
	091910-02-000	EA	BOX-ELECTRICAL - PLASTIC - 57 X 88MM
	008289-01-000	EA	BOX-ELECTRIC - STEEL - 4" X 4" - 1/2" & 3/4" KNOCKOUTS
	008289-02-000	EA	BOX-ELECTRICAL - 4" X 4" - 1/2" & 3/4" KNOCKOUTS - CANADIAN
	093603-01-000	EA	BOX-ELECTRICAL, 4" X 2 1/8" X 2 1/8" - STEEL
	008294-01-000	EA	COVER-ELECTRICAL BOX - BLANK/STEEL - 4" X 4" - GRAY
	008294-02-000	EA	COVER-ELECTRICAL BOX - BLANK STEEL - 4" X 4" - CANADIAN
	069238-01-000	EA	COVER-ELECTRICAL BOX - W/HOLE - 4" X 4" - GRAY USED WITH 30 AMP RECEPTACLE

ELECTRICAL CONNECTORS

KEY	PART NUMBER	U/M	DESCRIPTION
	077479-02-000	EA	BOOT-BATTERY TERMINAL - SINGLE CABLE
	008311-01-000	EA	CONNECTOR-WIRE NUT - INSULATED - RED
	008314-01-000	EA	CONNECTOR-WIRE NUT - INSULATED - GRAY
	008355-01-000	EA	CONNECTOR-CABLE CLAMPING - 3/4"
	008356-01-000	EA	CONNECTOR-PLASTIC - 3/8" AVG
	041480-01-000	EA	CONNECTOR-STRAIGHT - 1/2" FLEX CONDUIT
	082741-01-000	EA	CONNECTOR BODY-2 CNCT MALE - SERV ELEC 2P-FYL
	058028-01-000	EA	CONNECTOR-ELECTRICAL PIGTAIL - NYLON - CLEAR
	007093-01-000	EA	FLASHER-SIGNAL - STAT
	108669-01-000	EA	HOUSING-AUTO FUSE HOLDER - PACKARD 12010105
	063910-01-000	EA	HOUSING-RELAY - BOSCH 3 334 485 008
	088473-05-000	EA	HOUSING-PIN - 6 CAVITY - AMP 640585-1
	088473-06-000	EA	HOUSING-PIN - 6 CAVITY - AMP 1-480704-0
	088473-08-000	EA	HOUSING-PIN - 4 CAVITY - AMP 1-480702-0
	088473-09-000	EA	HOUSING-PIN - 3 CAVITY - AMP 1-480700-0
	088473-10-000	EA	HOUSING-PIN - 2 CAVITY - AMP 1-480698-0
	088474-06-000	EA	HOUSING-SOCKET - 6 CAVITY - AMP 1-480705-0
	088474-07-000	EA	HOUSING-SOCKET - 5 CAVITY - AMP 1-480764-0
	088474-08-000	EA	HOUSING-SOCKET - 4 CAVITY - AMP 1-480703-0
	088474-09-000	EA	HOUSING-SOCKET - 3 CAVITY - AMP 1-480701-0
	088474-10-000	EA	HOUSING-SOCKET - 2 CAVITY - AMP 1-480699-0
	106006-01-000	EA	HOUSING - 1 POSITION - FEMALE - PACKARD 12015952
	108355-01-000	EA	HOUSING - SWITCH - CARLING VCH
	104100-01-000	EA	HOUSING - 1 POSITION - 75 AMP - AMP 53884-1
	088475-01-000	EA	PIN-CONNECTOR - 14 TO 20 AWG
	088476-01-000	EA	SOCKET - CONNECTOR - BRASS - PRE-TIN
	008188-01-000	EA	SOLENOID - 3 POST - BATTERY CHANGE OVER
	104100-03-000	EA	TERMINAL - 75 AMP - AMP 53880-4 LOOSE
	047443-01-000	EA	TERMINAL -.250 RECEPTACLE FIT - INSULATED - 16/14 AWG
	106655-02-000	EA	TERMINAL-FUSE BLOCK - 10-12AWG
	106655-01-000	EA	TERMINAL-FUSE BLOCK - 14-16AWG - PACKARD 12020321
	062036-02-000	EA	TERMINAL-PACK-CON - 16/14 AWG
	035416-04-000	EA	TERMINAL-RING #10 STUD FIT - INSULATED BARREL #16/14
	008326-01-000	EA	TERMINAL-RING - 16/14 WIRE - 3/8" STUD
	008328-01-000	EA	TERMINAL-RING - 12/10 WIRE - #10 STUD FIT
	008331-01-000	EA	TERMINAL-RING -TONGUE - #4 WIRE - 3/8" STUD - COPPER
	008348-01-000	EA	TERMINAL-RING - 3/8" STUD - #2 WIRE CONNECTS CABLE TO DISCONNECT RELAY AND BATTERY
	113306-01-000	EA	TERMINAL-FEMALE, METRI-PACK - PACKARD 12048451
	113307-01-000	EA	TERMINAL-FEMALE, METRI-PACK - PACKARD 12048074

ELECTRICAL GROUP (CONTINUED)

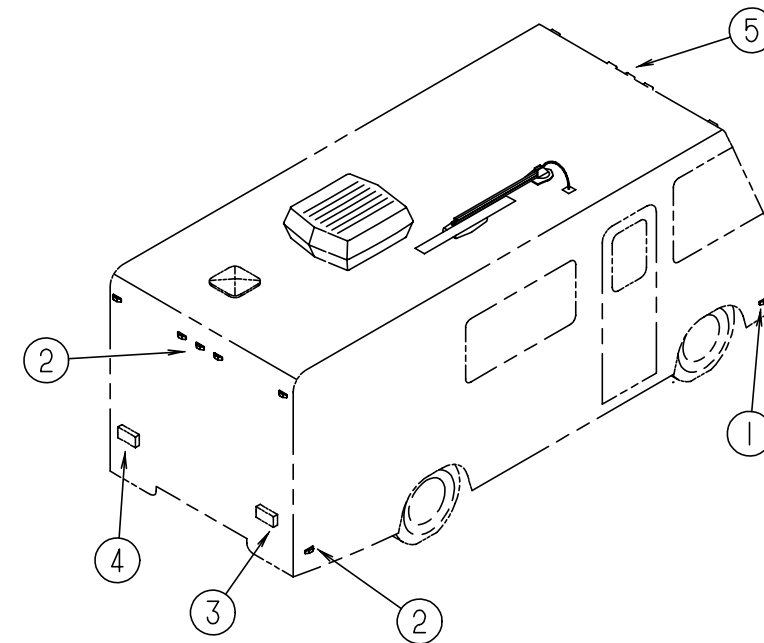

EXTERIOR LIGHTS

KEY	PART NUMBER	U/M	DESCRIPTION
1	111102-01-000	EA	BASE-CLEARANCE/SIDEMARKER LIGHT W/BULB - PLASTIC - WHITE
1	111102-02-000	EA	LENS-CLEARANCE/SIDEMARKER LIGHT - W/REFLEX - AMBER
1	036196-01-000	EA	BULB - 12V, #194 - .27AMP - BAYONETTE
1	091983-01-000	EA	GASKET-CLEARANCE/SIDEMARKER LIGHT
2	111102-01-000	EA	BASE-CLEARANCE/SIDEMARKER LIGHT - W/BULB - PLASTIC - WHITE
2	111102-03-000	EA	LENS - CLEARANCE/SIDEMARKER LIGHT - W/REFLEX - RED
2	008213-01-000	EA	BULB - 12 V - NO. 57 - .24 AMP
2	091983-01-000	EA	GASKET-CLEARANCE/SIDEMARKER LIGHT
3	110456-01-01A	EA	LAMP ASM-TAIL -COMBO BLACK - BARGMAN 30-91-110
4	110456-02-01A	EA	LAMP ASM-TAIL-COMBO W/BACKET - BARGMAN 30-91-111
	107256-01-03A	EA	COVER-TAIL LIGHT - BLACK
5	111102-01-000	EA	BASE-CLEARANCE/SIDEMARKER LIGHT W/BULB - PLASTIC - WHITE
5	111102-02-000	EA	LENS-CLEARANCE/SIDEMARKER LIGHT - W/REFLEX - AMBER
5	036196-01-000	EA	BULB - 12V, #194 - .27AMP - BAYONETTE
5	091983-01-000	EA	GASKET-CLEARANCE/SIDEMARKER LIGHT
5	109566-01-000	EA	BACKING-LIGHT - ROOF CAP
	070907-01-000	EA	HEADLAMP-RECTANGULAR - GM 5968097
	049359-01-000	EA	SPRING-RETAINER - HEADLAMP - GM 496096
	110750-01-000	EA	SCREW ASM-HEADLAMP ADJUSTING - T'MAN B62258-1428
	112823-01-000	EA	SPLICE-REDUCER - 16-14 TO 18-22

EXTERIOR BODY GROUP

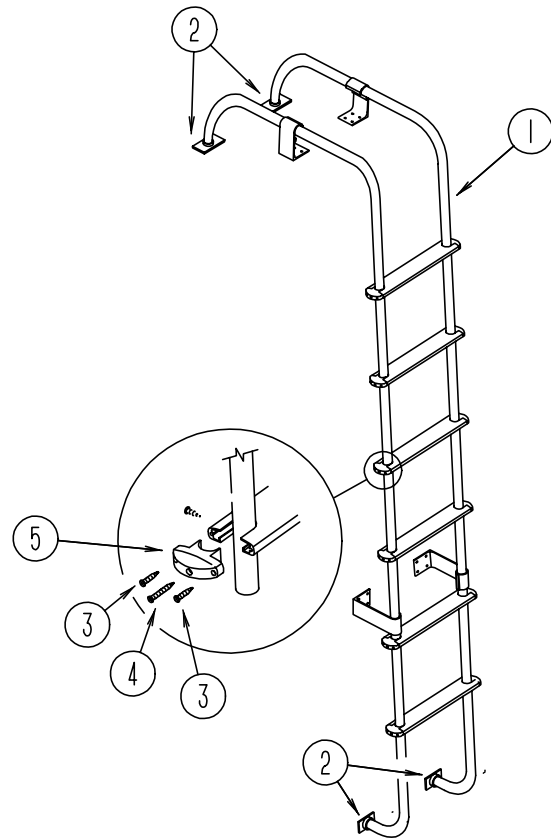

LADDER

KEY	PART NUMBER	U/M DESCRIPTION
1	102953-08-DB1	EA LADDER ASM
2	067165-01-000	EA BRACKET-MOUNTING, LADDER, LOWER
3	000G39-06-10T	EA SCREW-SELF DRIVING, 6-20 X 5/8" PPH - BLACK
4	000G67-10-36T	EA SCREW, 10-12 X 2.25" PPH - BLACK
5	076980-02-000	EA END CAP-STEP, BLACK
	069726-02-000	EA BUMPER - .88" DIAMETER X .40" - BLACK

FIBERGLASS, STYROFOAM, ALUMINUM & STEEL TUBING

KEY	PART NUMBER	U/M DESCRIPTION
	109838-04-01A	EA FIBERGLASS SHEET 2438 X 2463 OFF WHITE
	109838-06-01A	EA FIBERGLASS SHEET 2406 X 6558 OFF WHITE
	076054-P3-000	EA FIBERGLASS-SHEET 2438 X 2463 OFF WHITE
	076054-P4-000	EA FIBERGLASS SHEET 2438 X 2463 BRIGHT WHITE
	076054-N7-000	EA FIBERGLASS-SHEET 2406 X 7113 BRIGHT WHITE
	000870-06-000	SF STYROFOAM-PLANED, 1.34" X 48" X 96"
	083574-03-000	SF STYROFOAM, .75" X 48" X 96"
	055278-51-259	FT TUBING-STEEL, .75" X 1.5" X 12.5'
	033381-17-001	FT STEEL-TUBE, 16GA 1.5" X 1.5" X 288" - HOT FORMED ASTM A50
	002754-01-001	EA ANGLE-EXTRUDED, .75" X .75" X 18' - MILL ALUMINUM
	068716-01-001	EA BRACE - 90 DEGREE L-ANGLE, 192" - EXTRUDED ALUMINUM
	044487-01-001	EA SHEET-ALUMINUM, .019" X 96" X 360" - MILL FINISH
	044487-01-002	EA SHEET-ALUMINUM, .019" X 96" X 432" - MILL FINISH
	002726-01-001	EA GARNISH-U-CHANNEL, 1.38" X 19' - SERRATED - MILL ALUMINUM
	065747-01-000	SF INSULATION-MICROFOAM, .5" THICK X 72" X 112' ROLL
	089297-01-000	SF PLYWOOD-LUAN, OVERLAY GRADE - 4' X 8' - INC OF 32 SF

EXTERIOR BODY GROUP (CONTINUED)

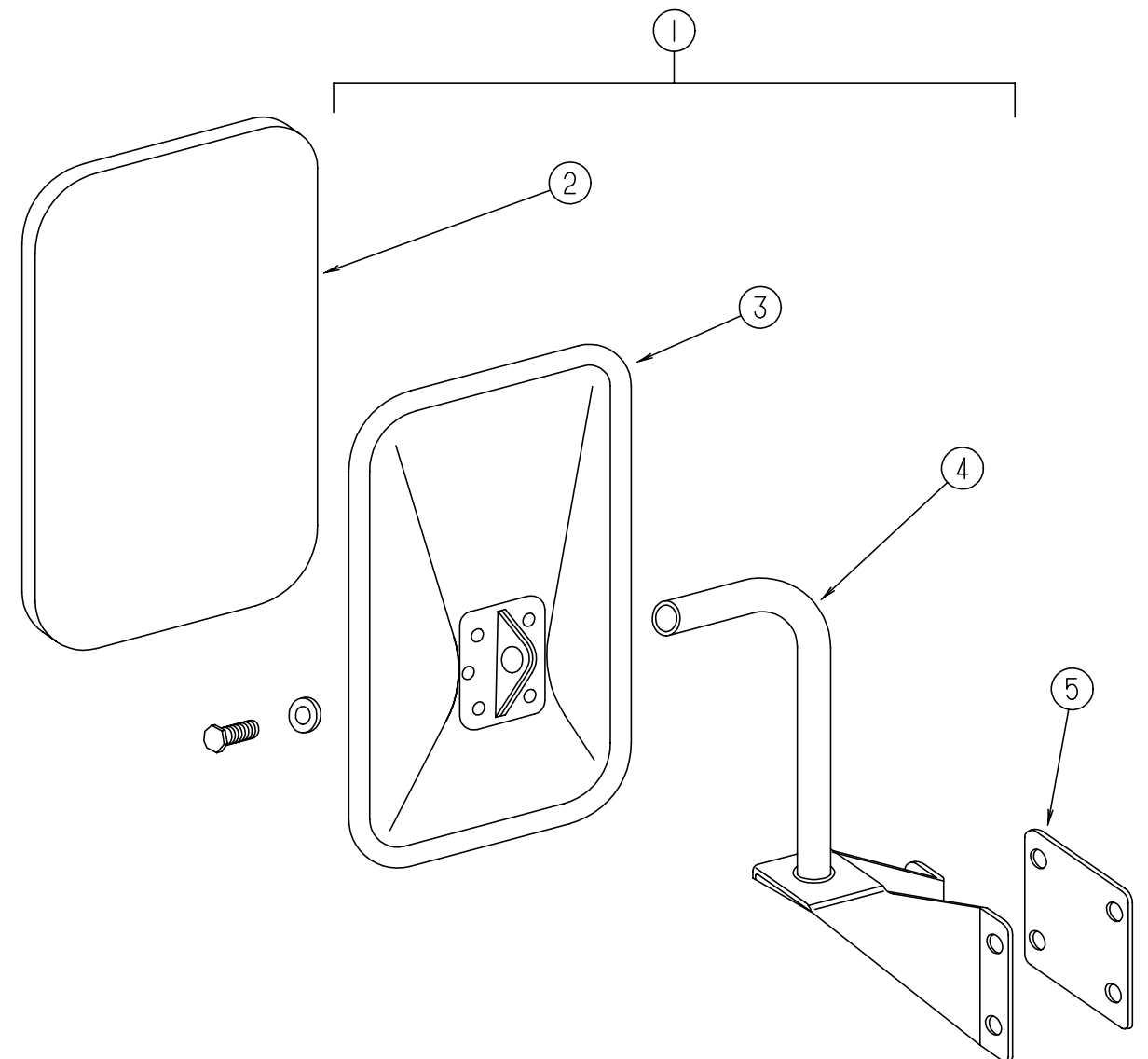

EXTERIOR MIRROR

KEY	PART NUMBER	U/M DESCRIPTION
1	105076-01-702	EA MIRROR ASM-LOW MOUNTING, BLACK - 713196
2	049347-01-700	EA GLASS-EXTERIOR MIRROR, 7.5" X 10.5"
3	105076-01-703	EA MIRROR HEAD ONLY, BLACK - 709001-8
4	105076-01-704	EA ARM, Q780521-9
5	110395-01-01A	EA PLATE-MIRROR, OFF WHITE
5	110395-01-02A	EA PLATE-MIRROR, MILL

EXTERIOR BODY GROUP (CONTINUED)

EXTERIOR BODY PANELS AND TRIM

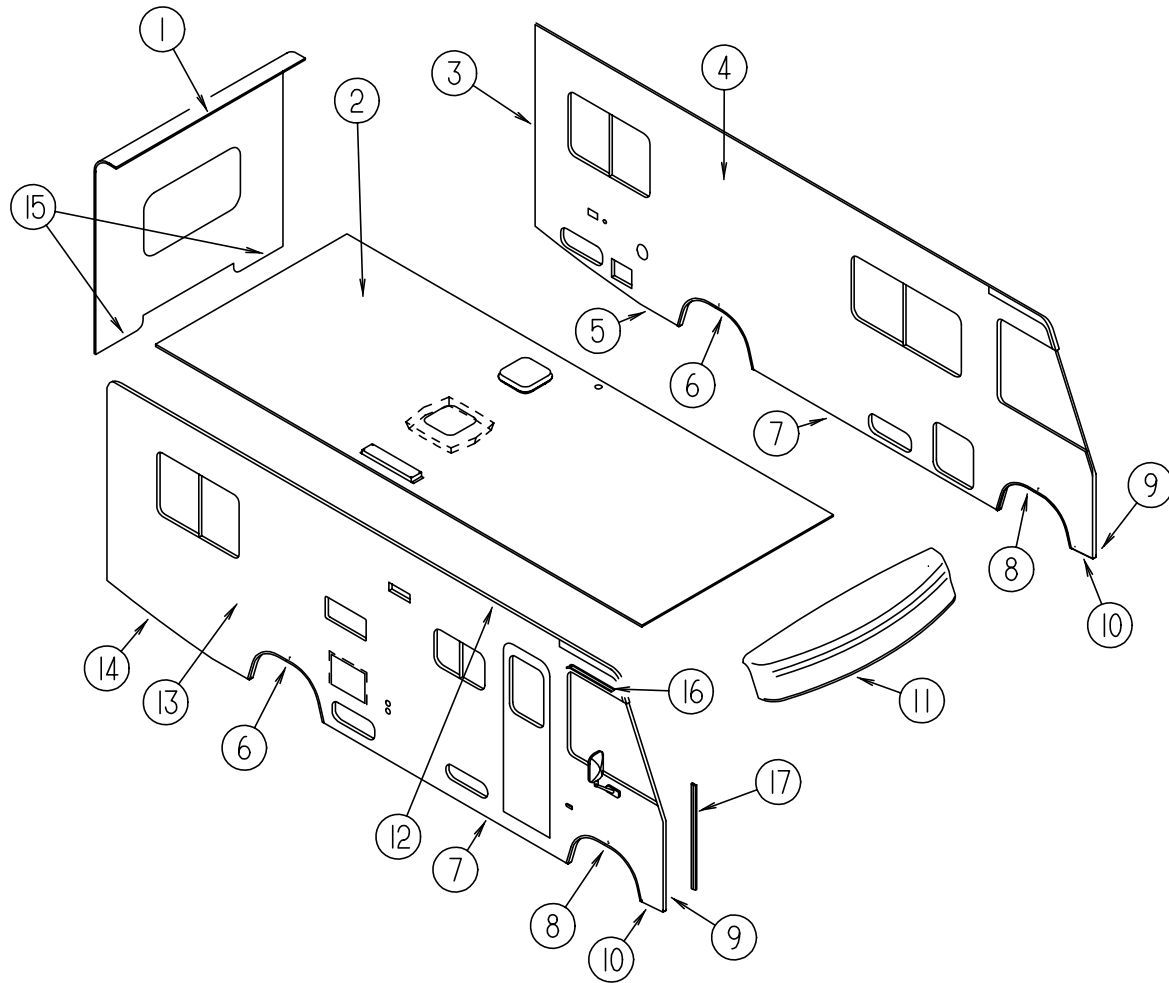

KEY	PART NUMBER	U/M	DESCRIPTION
1	M05961-19-FB1	EA	BACKWALL ASM, W/O WINDOW & TRIM - OFF WHITE
1	M05961-23-FB1	EA	BACKWALL ASM, W/O WINDOW & TRIM - BRIGHT WHITE
2	M05702-13-FB1	EA	ROOF ASM, W/O ROOF VENTS
3	096854-02-01A	EA	TRIM-CONTOUR, W/O VINYL INSERT - OFF WHITE
3	096854-02-02A	EA	TRIM-CONTOUR, W/O VINYL INSERT - BRIGHT WHITE
	105312-01-01A	FT	INSERT-CONTOUR TRIM, VINYL - OFF WHITE
	105312-01-07A	FT	INSERT-CONTOUR TRIM, VINYL - BRIGHT WHITE
4	P15015-01-FB1	EA	SIDEWALL ASM-DRIVER SIDE, W/O WINDOWS & TRIM - OFF WHITE
4	M07416-04-FB1	EA	SIDEWALL ASM-DRIVER SIDE, W/O WINDOWS & TRIM - BRIGHT WHITE
5	108038-06-01A	EA	TRIM-SIDEWALL, U-CHANNEL - 1830MM LONG - BOTTOM - REAR - OFF WHITE
5	108038-06-02A	EA	TRIM-SIDEWALL, U-CHANNEL - 1850MM LONG - BOTTOM - REAR - BRIGHT WHITE
6	108070-01-01A	EA	TRIM-WHEELWELL, REAR - OFF WHITE
6	108070-01-04A	EA	TRIM-WHEELWELL, REAR - BRIGHT WHITE
7	108039-01-01A	EA	TRIM-SIDEWALL, U-CHANNEL -3065MM LONG - BOTTOM - CENTER-OFF WHITE
7	108039-01-04A	EA	TRIM-SIDEWALL, U-CHANNEL - 3065MM LONG - BOTTOM - CENTER-BRIGHT WHITE
8	108069-01-01A	EA	TRIM-WHEELWELL, FRONT - OFF WHITE
8	108069-01-04A	EA	TRIM-WHEELWELL, FRONT - BRIGHT WHITE
9	086180-55-001	EA	U-CHANNEL-EXTRUDED, 1.7" X 16' - OFF WHITE - SERRATED
10	108109-01-01A	EA	TRIM-SIDEWALL, U-CHANNEL - 247MM LONG - LOW - FRONT - OFF WHITE
10	108109-01-04A	EA	TRIM-SIDEWALL, U-CHANNEL - 247MM LONG - LOW - FRONT - BRIGHT WHITE
11	M05922-02-EB1	EA	CAP ASM-FRONT, W/CLEARANCE LIGHTS & WIRING - OFF WHITE
11	M05922-02-FB1	EA	CAP ASM-FRONT, W/CLEARANCE LIGHTS & WIRING - BRIGHT WHITE
	109914-01-01A	EA	CAP-FRONT, W/O WIRING & CLEARANCE LIGHTS - OFF WHITE
	109914-01-02A	EA	CAP-FRONT, W/O WIRING & CLEARANCE LIGHTS - BRIGHT WHITE
12	109936-02-01A	EA	RAIL-AWNING, 3061MM LONG - OFF WHITE
12	109936-02-02A	EA	RAIL-AWNING, 3061MM LONG - BRIGHT WHITE
13	P15014-01-FB1	EA	SIDEWALL ASM-PASSENGER SIDE - W/O WINDOWS & DOORS OFF WHITE
13	M07416-03-FB1	EA	SIDEWALL ASM-PASSENGER SIDE - W/O WINDOWS & DOORS BRIGHT WHITE
14	108038-07-01A	EA	TRIM-SIDEWALL, U-CHANNEL - 1830MM LONG - BOTTOM - REAR - OFF WHITE
14	108038-07-02A	EA	TRIM-SIDEWALL, U-CHANNEL - 1850MM LONG - BOTTOM - REAR - BRIGHT WHITE
15	050406-15-000	EA	TRIM-BACKWALL, LOWER - OFF WHITE
15	050406-21-000	EA	TRIM-BACKWALL, LOWER - BRIGHT WHITE
16	108274-03-01A	EA	RAIL-DRIP, EXTRUDED ALUMINUM - PASSENGER FRONT WINDOW-OFF WHITE
16	108274-03-02A	EA	RAIL-DRIP, EXTRUDED ALUMINUM - PASSENGER FRONT WINDOW-BRIGHT WHITE
	108274-04-01A	EA	RAIL-DRIP, EXTRUDED ALUMINUM - DRIVERS FORNT WINDOW- OFF WHITE
	108274-04-02A	EA	RAIL-DRIP, EXTRUDED ALUMINUM - DRIVERS FORNT WINDOW- BRIGHT WHITE
17	089922-21-000	EA	TRIM-FIBERGLASS, PANEL - OFF WHITE
17	089922-26-000	EA	TRIM-FIBERGLASS, PANEL - BRIGHT WHITE
	108688-01-01A	EA	STRIP-FEATURE, OFF WHITE (LOWER BACKWALL)
	108688-01-03A	EA	STRIP-FEATURE, BRIGHT WHITE (LOWER BACKWALL)
	108651-01-01A	EA	END CAP-FEATURE STRIP, MILL (LOWER BACKWALL)

EXTERIOR BODY GROUP (CONTINUED)

DECALS, FILM STRIPES & PAINT

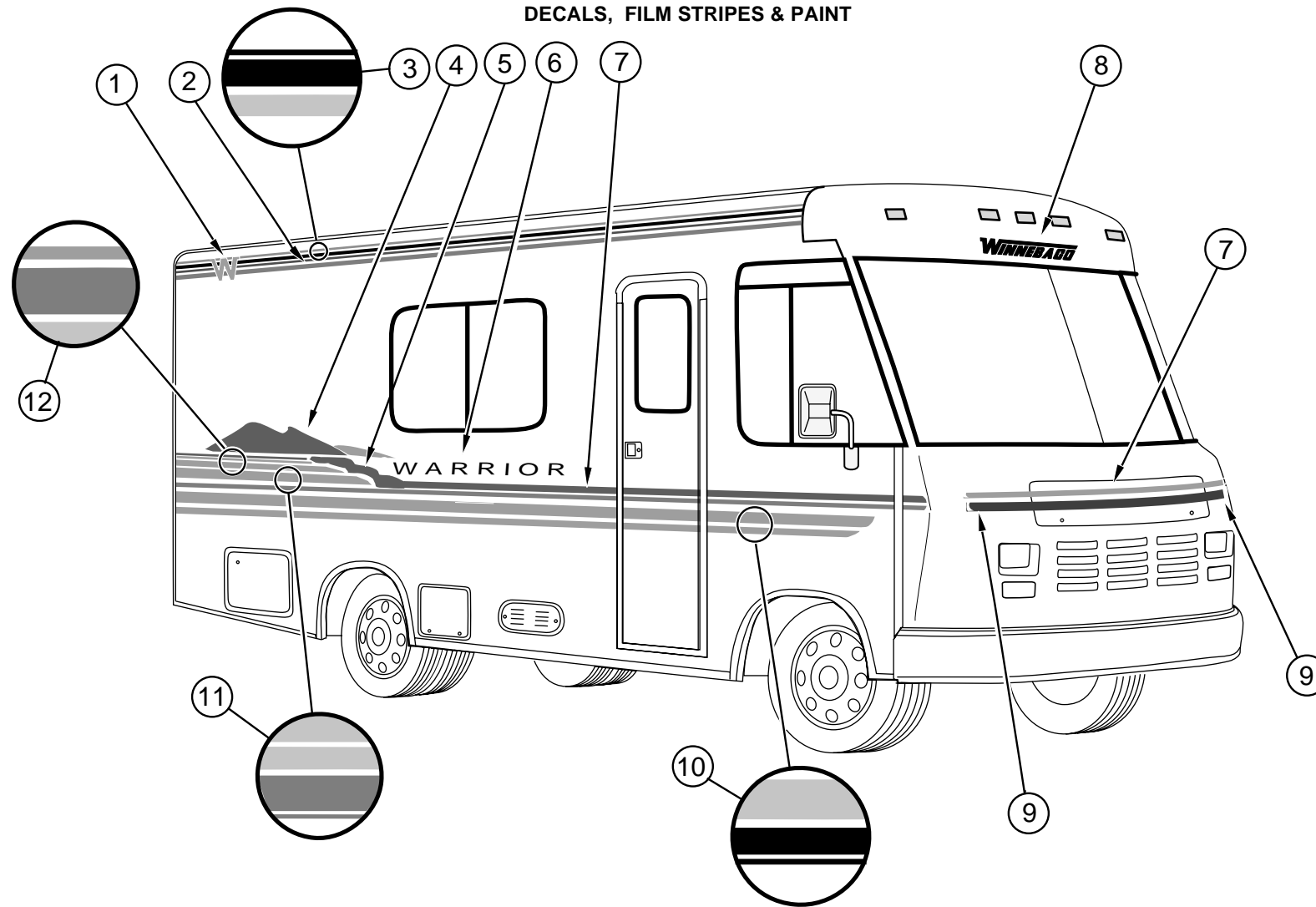

KEY	PART NUMBER	U/M	DESCRIPTION	
1	114793-01-01A	EA	DECAL-LOGO, "W"	LIGHT MARINE BLUE
2	107385-02-07A	FT	FILM-MULTISTRIPE 50.8MM X 150"	MARINE BLUE
3	094443-24-01A	FT	FILM-MULTISTRIPE 69.9MM X 150'	MDBLUE/MEDIUM BLUE/VIOLET
4	114792-01-01A	EA	DECAL-MOUNTAINS, PASSENGERS	DK PURPLE/VIOLET
	114792-02-01A	EA	DECAL-MOUNTAINS, DRIVERS	DK PURPLE/VIOLET
5	114794-02-01A	EA	DECAL-ROLLING HILLS, DRIVERS	SILVER/MARINE BLUE
	114794-01-01A	EA	DECAL-ROLLING HILLS, PASSENGERS	SILVER/MARINE BLUE
6	110399-01-02A	EA	DECAL-WARRIOR	MEDIUM BLUE/VIOLET
7	107385-11-04A	FT	FILM-31.8MM X 150FT	MEDIUM BLUE
8	050313-62-000	EA	DECAL-LOGO,WINNEBAGO,2.80	MEDIUM BLUE
9	107385-06-05A	FT	FILM-25.4MM X 150FT	VIOLET
10	094443-30-01A	FT	FILM-MULTISTRIPE 187.3MM X 150	LT MARINE BLUE/MARINE BLUE
11	094443-23-01A	FT	FILM-MULTISTRIPE 142.9MM X 150	SEMSTEAL/MARBLUE/MARINE
12	105781-11-07A	FT	FILM-MULTISTRIPE 50.8MM X 150'	SILVER/LT MARINE BLUE
	041561-03-000	EA	PAINT-LOW BAKE, OFF WHITE	REF:72897-01
	044486-03-000	EA	PAINT-LOW BAKE, BEIGE	REF:72897-02
	083581-03-000	GL	PAINT-OFF WHITE, USE DUPONT	L8723 TO OBTAIN LOCALLY

EXTERIOR BODY GROUP (CONTINUED)

FRONT END COMPONENTS

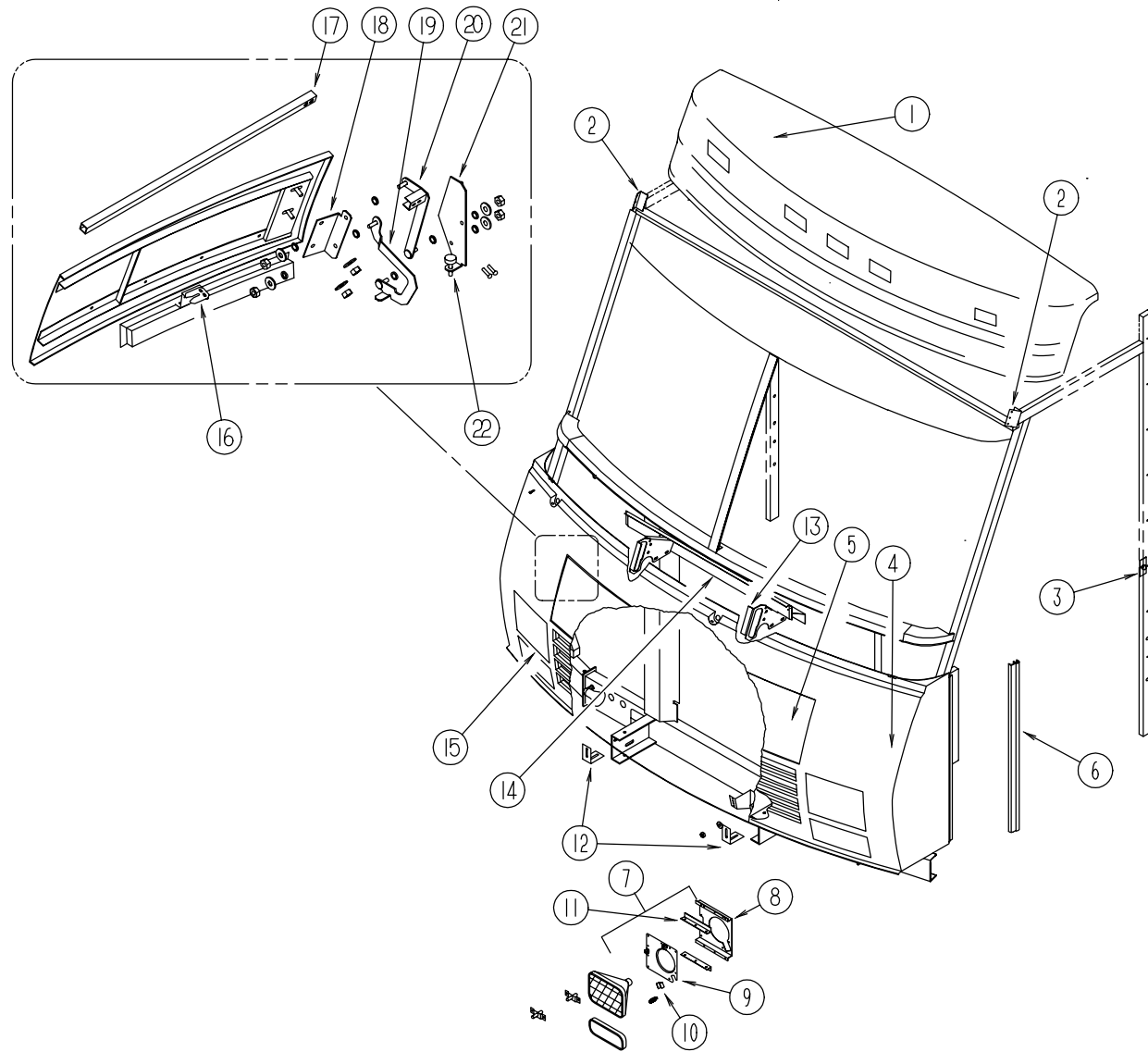

KEY	PART NUMBER	U/M	DESCRIPTION
1	M05922-02-EB1	EA	CAP ASM-FRONT, W/CLEARANCE LIGHTS OFF WHITE
1	M05922-02-FB1	EA	CAP ASM-FRONT, W/CLEARANCE LIGHTS - BRIGHT WHITE
	109914-01-01A	EA	PANEL-ROOF CAP, OFF WHITE - W/O LIGHTS
	109914-01-02A	EA	PANEL-ROOF CAP, BRIGHT WHITE - W/O LIGHTS
2	077001-01-000	EA	ANGLE-MOUNTING, ROOF PANEL - V ANGLE - 3" X 2.4" X 1.5"
3	070579-06-000	EA	PLATE-ANCHOR, W/7/16 WELD NUT - 1.5" X 3.3"
4	M05928-01-DB1	EA	FRONT END ASM-FIBERGLASS, COMPLETE W/HEADLIGHTS - OFF WHITE
4	M05928-01-FB1	EA	FRONT END ASM-FIBERGLASS, COMPLETE W/HEADLIGHTS - BRIGHT WHITE
5	109931-01-DB1	EA	PANEL ASM-HOOD, W/O LOCK - OFF WHITE - SEPERATE FROM FRONT END
5	109931-01-FB1	EA	PANEL ASM-HOOD, W/O LOCK - BRIGHT WHITE - SEPERATE FROM FRONT END
6	089922-21-000	EA	TRIM-FIBERGLASS, PANEL - OFF WHITE
6	089922-26-000	EA	TRIM-FIBERGLASS, PANEL - BRIGHT WHITE
7	110712-02-D15	EA	PLATE ASM-HEADLAMP, DUAL -LEFT
8	110784-02-01A	EA	BRACKET-HEADLAMP, DUAL - LEFT - MILL
	110784-01-01A	EA	BRACKET-HEADLAMP, DUAL - RIGHT - MILL
9	110711-02-01A	EA	PLATE-HEADLAMP, DUAL - LEFT - MILL
	110711-01-01A	EA	PLATE-HEADLAMP, DUAL - RIGHT - MILL
10	110691-01-01A	EA	BRACKET-SPRING, HEADLAMP - MILL
11	110782-01-000	EA	ANGLE-SUPPORT, HEADLAMP - V-ANGLE - 160MM LONG
12	103628-01-000	EA	BRACKET-FRONT, LOWER - MOUNTING
13	103136-02-000	EA	BRACKET-SUPPORT, UPPER - HINGE - LEFT
	103136-01-000	EA	BRACKET-SUPPORT, UPPER - HINGE - RIGHT
14	102421-01-000	EA	PANEL-PLENUM, CENTER
15	110712-01-D15	EA	PLATE ASM-HEADLAMP, DUAL - RIGHT
16	109915-01-01A	EA	LATCH-HOOD, FRONT END - BLACK
17	105096-05-000	EA	TUBE-TIMING, HOOD HINGE
18	109927-01-000	EA	ANGLE-LINK, HOOD - RIGHT
	109927-02-000	EA	ANGLE-LINK, HOOD - LEFT
19	109930-03-000	EA	LINK ASM-HINGE, HOOD - LOWER - RIGHT - W/ WELD STUD
	109930-01-000	EA	LINK ONLY-HINGE, HOOD - LOWER - RIGHT
	109930-04-000	EA	LINK ASM-HINGE, HOOD - LOWER - LEFT - W/ WELD STUD
	109930-02-000	EA	LINK ONLY-HINGE, HOOD - LOWER - LEFT
20	109929-01-000	EA	LINK ASM-HINGE, HOOD - UPPER - RIGHT
	109929-02-000	EA	LINK ASM-HINGE, HOOD - UPPER - LEFT
21	109926-03-000	EA	BRACKET ASM-LINK, HINGE - RIGHT - W/WELD STUD & FERRULE
	109926-01-000	EA	BRACKET ONLY-LINK, HINGE - HOOD - RIGHT
	109926-04-000	EA	BRACKET ASM-LINK, HINGE - LEFT - W/WELD STUD & FERRULE
	109926-02-000	EA	BRACKET ONLY-LINK, HINGE - HOOD - LEFT
22	058786-01-000	EA	BOLT-ADJUSTING, HOOD - W/BLACK PAD - .31" #18 X 2"
22	000D39-05-00B	EA	NUT-HEX, SERRATED FLANGE LK - 5/16 - 18 - ZINC

GALLEY GROUP

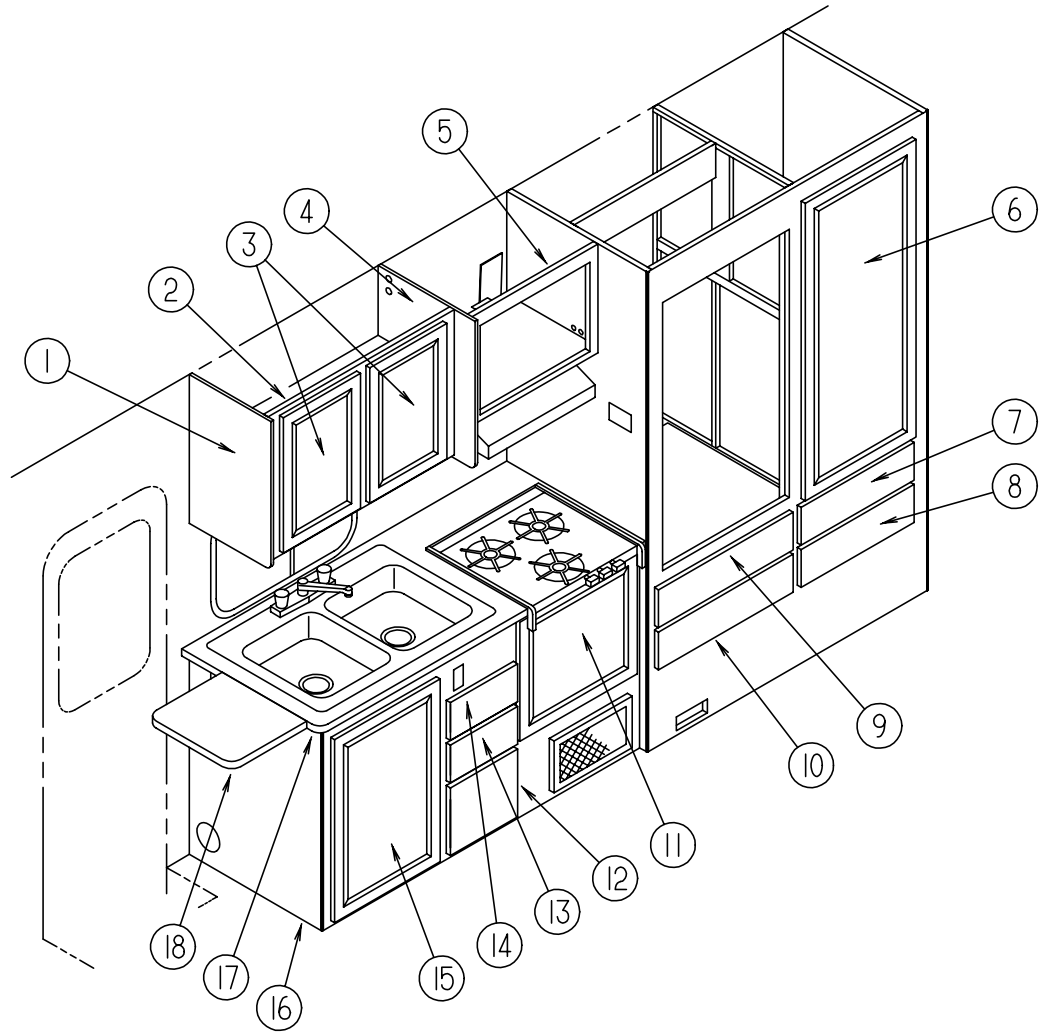

GALLEY CABINETRY

KEY	PART NUMBER	U/M DESCRIPTION
1	109908-06-EB1	EA CAP ASM-END - OVERHEAD
2	109919-02-FB1	EA CABINET ASM-OVERHEAD - GALLEY
3	M05930-10-F15	EA DOOR ASM-MITERED - VINYL WRAP 0365 X 0555
4	109908 05 EB1	EA CAP ASM-END - OVERHEAD
5	115114-04-FB1	EA CABINET ASM-MICROWAVE OVERHEAD
		FROM: 00-00-00 THRU: 08-02-94
5	115114-02-FB1	EA CABINET ASM-MICROWAVE OVERHEAD
		FROM: 08-03-94 THRU 99-99-99
6	M05930-11-FB1	EA DOOR ASM-MITERED - VINYL WRAP - REFRIGERATOR CABINET 0525 X 1220
7	P10163-04-EB1	EA DRAWER COMPLETE-SLIDE - REFRIGERATOR CABINET
8	P10163-10-EB1	EA DRAWER COMPLETE-SLIDE - REFRIGERATOR CABINET
9	P10163-05-FB1	EA DRAWER COMPLETE-SLIDE - REFRIGERATOR CABINET
10	P10163-03-EB1	EA DRAWER COMPLETE-SLIDE - REFRIGERATOR CABINET
11	M05930-17-EB1	EA DOOR ASM-MITERED - VINYL WRAP
12	P10163-07-EB1	EA DRAWER COMPLETE-SLIDE
13	P10163-06-EB1	EA DRAWER COMPLETE-SLIDE
14	P10163-53-EB1	EA DRAWER COMPLETE-SLIDE
15	M05937-58-EB1	EA DOOR ASM-MITERED - VINYL WRAP
16	P10121-01-FB1	EA CABINET ASM-GALLEY
	109799-01-01A	EA FAUCET-GALLEY - DUAL CONTROL
	109688-01-000	EA SINK-STAINLESS STEEL - DOUBLE - 33 X 22 - ELKAY KFJ5023322
	092303-01-000	EA STRAINER-SINK
	110012-01-FB1	EA COVER ASM-SINK
17	110121-11-FB1	EA COUNTERTOP ASM
18	080812-06-FB1	EA EXTENSION ASM-GALLEY
	104181-01-01A	EA SUPPORT-LEAF - 5.3" - EXTENDS TO 7.5" - SAFTY RING - METAL

GALLEY GROUP (CONTINUED)

REFRIGERATOR

KEY	PART NUMBER	U/M DESCRIPTION
	102621-04-01A	EA REFRIGERATOR-LARGE SINGLE DOOR 2-WAY - NORCOLD 6052 RIGHT
	064473-01-702	EA ORIFICE-NORCOLD 61452122
	064473-03-701	EA HEATER AC - HORIZONTAL BURNER - NORCOLD 615625
	064473-03-718	EA COOLING UNIT-HORIZONTAL BURNER - NORCOLD 61687137
	075217-01-734	EA FUSE- 3 AMP - NORCOLD 61538822
	084880-01-718	EA VALVE-GAS - NORCOLD 61551822
	084880-01-720	EA SPRING (FOR DOOR HANDLE) - 61558822
	084880-01-722	EA CRISPER COVER - NORCOLD 615641
	084880-01-732	EA LATCH - NORCOLD 61578522
	084880-01-740	EA END CAP - STOP CATCH - NORCOLD 61593830
	084880-01-746	EA CABLE - NORCOLD 61571522
	084880-01-753	EA THERMISTER 78" W/CLIP - NORCOLD 61693822
	084880-01-760	EA CLIP-THERMISTER - NORCOLD 61689122
	084880-01-761	EA END CAP - SPRING CATCH - BLACK - NORCOLD 61593730
	084880-03-702	EA HINGE PIN TOP/BOTTOM FEMALE - NORCOLD 61580630
	094039-01-704	EA PLATE-HINGE - BLACK - NORCOLD 61631430
	094039-01-710	EA PLATE-HINGE - BLACK - NORCOLD 61631330
	094039-01-713	EA DOOR GASKET - LOWER - GRAY - NORCOLD 61568030
	094039-01-715	EA LOWER DOOR LINER - BLACK/WHITE - NORCOLD 61581738-B
	094039-01-717	EA LOWER DOOR HANDLE ASSEMBLY - BLACK - NORCOLD 61649938
	094039-01-722	EA HOLE PLUG - BLACK - HINGE HOLES - NORCOLD 61582030
	094039-01-723	EA HINGE BRACKET -TOP RIGHT-BOTTOM LEFT BLACK - NORCOLD 61580838
	094039-01-724	EA BRACKET-HINGE - TOP LEFT - BOTTOM RIGHT - BLACK - NORCOLD 61580938
	094039-01-725	EA HINGE PIN - BLACK - MALE - NORCOLD 61578130
	094039-01-732	EA FRONT COVER - BLACK BOTTOM TRIM - NORCOLD 61622130
	094039-01-739	EA SHELF - CUTOUT - NORCOLD 61646722
	094039-04-700	EA PRINTED CIRCUIT BOARD-2 WAY - NORCOLD 61647322
	094039-04-701	EA EYEBROW - SHELL - 2 WAY - NORCOLD 61669822
	094039-04-702	EA POWER SUPPLY - 2 WAY - NORCOLD 61647422
	102621-01-700	EA EVAPORATOR DOOR ASM - NORCOLD 61620738
	102621-01-701	EA FOAMED CAB ASM - BLACK - NORCOLD 61620238
	104137-02-700	EA MODULE-CONTROL - CHANNEL - NORCOLD 61717037
	102621-04-703	EA HOLDER-SPRING-RIGHT - WHITE - NORCOLD 61632830
	102621-04-704	EA TRAY-DRIP - WHITE - NORCOLD 61619930
	102621-04-705	EA RETAINER FOR GLASS SHELF - NORCOLD 61580322
	102621-04-706	EA SPRING -TORSION - LEFT - EVAPORATOR DOOR - NORCOLD 61633122
	102621-04-707	EA HOLDER -SPRING LEFT - WHITE EVAPORATOR - NORCOLD 61632730
	102621-04-708	EA CLIP MOUNTING - LEFT - WHITE - EVAPORATOR DOOR - NORCOLD 61633030
	102621-04-709	EA CLIP MOUNTING - RIGHT - WHITE - EVAPORATOR DOOR - NORCOLD 61632930
	102621-04-710	EA SPRING PIN - NORCOLD 61632622
	102621-04-711	EA SPRING TORSION - RIGHT - EVAPORATOR DOOR - NORCOLD 61633222
	102621-04-712	EA HEATER -DC - HORIZONTAL BURNER - NORCOLD 61562622
	104137-06-703	EA BIN-DOOR SHELF - WHITE - NORCOLD 61564025
	104137-06-704	EA BIN-MILK - WHITE - NORCOLD 61579425
	104137-06-705	EA HANDLE -LOWER DOOR W/DECAL - NORCOLD 61666622
	104137-06-706	EA WIRE SHELF - SHORT - NORCOLD 61718222
	104137-06-707	EA CRISPER - WHITE - NORCOLD 61571325
	104137-06-709	EA VALVE SHUT-OFF-MANUAL ASM - NORCOLD 61694922
	104137-06-710	EA PRESSURE TAP - NORCOLD 61594422
	104137-06-711	EA FUSE - 5 AMP - NORCOLD 61611622
	104137-06-712	EA FITTING-GAS TUBE CONNECTION - NORCOLD 61692722
	104137-06-713	EA ORFICE GASKET - NORCOLD 61475122
	104137-06-714	EA BURNER ASSEMBLY (5-SLOT) - NORCOLD 61705222
	104137-06-715	EA SPARK/SENSE ELECTRODE - SINGLE - NORCOLD 61692222
	054450-01-000	EA LEVEL-REFRIGERATOR
	065225-03-000	EA PLATE-TIEDOWN - REFRIGERATOR
	093646-05-000	EA BRACKET ASM-TIEDOWN - REFRIGERATOR

GALLEY GROUP (CONTINUED)

MICROWAVES, RANGE HOOD, & MONITOR PANEL

KEY	PART NUMBER	U/M	DESCRIPTION
	091269-05-000	EA	OVEN-MICROWAVE FROM: 00-00-00 THRU: 08-02-94
	093646-05-000	EA	BRACKET ASM-TIEDOWN,REFRIG FROM: 00-00-00 THRU: 08-02-94
	094745-01-01A	EA	TRIM-MICROWAVE BLACK FROM: 00-00-00 THRU: 08-02-94
	094750-01-000	EA	BRACKET-MICROWAVE, 90 DEGREE FROM: 00-00-00 THRU: 08-02-94
	094774-03-01A	EA	TRIM-MICROWAVE,BLACK FROM: 00-00-00 THRU: 08-02-94
	115303-01-000	EA	OVEN-MICROWAVE FROM: 08-03-94 THRU 99-99-99
	115401-01-01A	EA	TRIM-MICROWAVE BLACK FROM: 08-03-94 THRU 99-99-99
	094750-07-000	EA	BRACKET-MICROWAVE, 89 DEGREE FROM: 08-03-94 THRU 99-99-99
	100258-10-01A	EA	METER-HOUR - VENTLINE 150
	103386-01-01A	EA	HOOD-RANGE - NON-POWERED - BLACK - VENTLINE
	092696-01-710	EA	SOCKET-LIGHT - VENTLINE CB267-2
	103386-01-700	EA	SWITCH-PUSH BUTTON - V199-3
	109934-01-01A	EA	PANEL-MONITOR 1 TANK BLACK - LVS W/PLUG
	096983-01-700	EA	SWITCH-ON/OFF - VENTLINE 108
	075470-01-703	EA	SWITCH-ON/MOMENTARY - JENSEN RP1016
	100258-10-01A	EA	METER-HOUR - VENTLINE 150

RANGE

KEY	PART NUMBER	U/M	DESCRIPTION
	110404-01-01A	EA	RANGE - 3 BURNER W/O OVEN - WEDGEWOOD D35S
	101593-01-701	EA	SCREW-THUMB, WEDGEWOOD 52537
	101593-01-703	EA	KNOB-BURNER, WEDGEWOOD 53000
	101593-01-704	EA	VALVE-BURNER, WEDGEWOOD 52506
	110404-01-700	EA	GRATE-REAR DESIGNER - 53303
	110404-01-701	EA	GRATE-FRONT DESIGNER - 53302
	110404-01-702	EA	TOP-COOK

GENERATOR GROUP

4000 KW ONAN GENERATOR

KEY	PART NUMBER	U/M	DESCRIPTION
	100974-01-000	EA	GENERATOR - 4.0KW EMERALD PLUS - ONAN BGE-FA/26100G
	105958-06-000	EA	PIPE-EXHAUST - GENERATOR - BAUER WELDING
	079654-05-000	EA	PIPE-EXHAUST - ANGLED - W/FLANGE - 2" ID - ONAN# 154-2539
	093591-02-000	EA	PIPE-EXHAUST - GENERATOR - CURVED - 1.5" OD
	081364-03-000	EA	MUFFLER-GENERATOR - ONAN
	007125-03-000	EA	CLAMP - MUFFLER - 1.5"
	007125-04-000	EA	CLAMP - MUFFLER - 1.1"
	094059-01-000	EA	SPACER-GENERATOR - ONAN
	105732-01-000	EA	TRAY ASM-GENERATOR
	007067-01-000	SF	INSULATION-FIBERGLASS - 1" THICK X 4' - INCREMENTS OF 4 SF
	106607-01-000	EA	ANGLE-SUPPORT - EXHAUST
	007131-01-000	EA	HANGER-TAILPIPE - 6 SLOTS

HEATING & AIR CONDITIONING GROUP

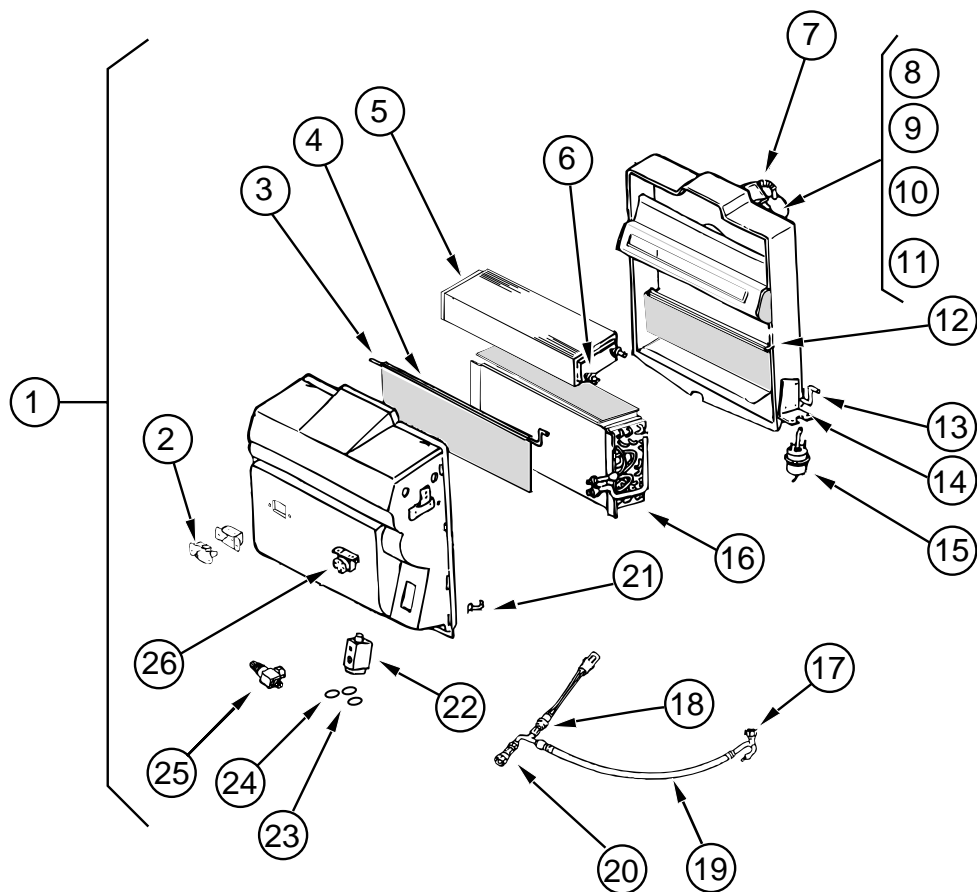

AUTO A/C - EVAPORATOR/HEATER

KEY	PART NUMBER	U/M DESCRIPTION
1	103930-20-000	EA EVAP/HEATER CHEV R134A BLOCK SCS 090-00083
2	103930-01-710	EA RESISTOR-FUSED, SCS 035-0006
3	103930-20-702	EA ROD - FRONT BLEND AIR DOOR
4	103930-20-703	EA DOOR - BLEND AIR
5	103930-01-703	EA COIL-HEATER, SCS 042-0010
6	110279-01-712	EA HEATER FITTING 050-0076
7	110279-01-703	EA HOSE-VENT, MOTOR BLOWER - SCS 051-0034
8	103930-20-707	EA BLOWER - HOUSING
9	103930-01-720	EA MOTOR, SCS 030-0004
10	103930-01-717	EA WHEEL-CLOCKWISE, SCS 062-0010
11	103930-20-708	EA CLIP - FRONT MOTOR SHAFT
12	103930-20-705	EA DOOR - PANEL - RECIRCULATING
13	103930-20-704	EA ROD - DOOR- RECIRCULATING
14	103930-01-708	EA BRACKET-VACUUM MOTOR, SCS 070-0113
15	103930-02-708	EA MOTOR-VACUUM SERVO, A/C - SCS 030-0002
16	103930-01-704	EA COIL EVAPORATOR
17	103930-12-708	EA SWITCH-BINARY, R-134A - SCS 032-0048
18	103930-01-716	EA SWITCH-PRESSURE, FAN - SCS 032-0036
19	103930-20-701	EA HOSE ASSY #6 WINN GM 085-0138
20	103930-12-709	EA FITTING-QUICK CONNECT SCS 050-0120
21	103930-20-706	EA CLIP - RETAINER
22	103930-20-700	EA VALVE EXP. BLOCK(2 TON) 034-0032
23	103930-17-702	EA GASKET OR SAE 015 #10 33-781, SCS 045-0127
24	113245-01-707	EA GASKET(#8) 045-0126
25	103930-20-709	EA SERVICE VALVE
26	103930-01-711	EA THERMOSTAT, SCS 033-0003
	103930-17-000	EA HOSE KIT #10 GM-SANDEN COMP SCS 093-00076
	103930-17-700	EA FTG. PAD COMP. SUCTION SAN 050-0131
	103930-17-701	EA FTG #10.90 W/FERRULE/1342CP 050-0132
	103930-17-703	EA GASKET-SEAL,SANDEW COMP33-76 045-0142
	103930-17-704	EA HOSE ASSY #10 085-0113
	007281-01-000	EA HOSE-FLEXIBLE PVC, 2.5"ID X 50' - ATCOFLEX A-182-355
	024990-05-000	EA 4" DIAMETER OUTLET W/SWIVEL DEFLECTORS
	056402-05-000	EA BRACKET-HEATER VENT, ROUND - W/BEND - BLACK

HEATING & AIR CONDITIONING GROUP (CONTINUED)

GAS AUTO A/C - CONTROL PLENUM

KEY	PART NUMBER	U/M DESCRIPTION
	103930-04-000	EA CONTROL/PLENUM SET, SCS 093-00037
	049401-01-700	EA VALVE-WATER CONTROL, SCS 22498
	072341-06-700	EA SWITCH - 4 SPEED, FAN - ARA 0883502
	094831-01-707	EA WIRING HARNESS-UNIT, MOTIVAIR/SCS ZGG15050
	094831-01-746	EA CLAMP-BLEND CABLE, MOTIVAIR/SCS 77000-00
	103930-02-708	EA MOTOR-VACUUM SERVO, A/C - SCS 030-0002
	103930-02-700	EA ROD-AIR BLEND DOOR, SCS 073-0017
	103930-02-702	EA DECAL-FAN SWITCH, SCS 058-0008
	103930-02-703	EA HARNESS-WIRE CONTROL, SCS 036-0048
	103930-02-707	EA RELAY, SCS 031-0001
	103930-02-710	EA CANISTER-VACUUM, SCS 054-0002
	103930-11-700	EA CABLE, DOUBLE - RING W/HOOK - SCS 074-0003
	072341-06-700	EA SWITCH - 4 SPEED, FAN - ARA 0883502
	094831-01-709	EA CLAMPS-ROD, 3/16" - MOTIVAIR/SCS ZGG14431
	103930-02-701	EA VALVE-CONTROL HEAD, SCS 034-0015
	103930-02-704	EA HARNESS-VACUUM CONTROL, SCS 036-0049
	103930-02-705	EA CABLE-CONTROL, BOWDEN - SCS 074-0011
	103930-02-706	EA CLIP-CABLE, CONTROL - SCS 022-0017
	103930-02-708	EA MOTOR-VACUUM SERVO, A/C - SCS 030-0002
	103930-02-711	EA VALVE-WATER, SCS 034-00114

GAS AUTO A/C - HOSE KIT

KEY	PART NUMBER	U/M DESCRIPTION
	103930-17-000	EA HOSE KIT, 10 GM-SANDEN COMPRESSOR - SCS 093-00076
	103930-01-708	EA BRACKET-VACUUM MOTOR, SCS 070-0113
	103930-17-700	EA PAD-FITTING, SANDEN COMPRESSOR SUCTION - SCS 050-0131
	103930-17-701	EA FITTING - 10.90, W/FERRULE - 1342CP - SCS 050-0132
	103930-17-702	EA GASKET OR SAE 015 10 33-781, SCS 045-0127
	103930-17-703	EA GASKET-SEAL, SANDEN COMPRESSOR 33-76 - SCS 045-0142

GAS AUTO A/C SYSTEM

KEY	PART NUMBER	U/M DESCRIPTION
	007281-01-000	EA HOSE-FLEXIBLE PVC, 2.5"ID X 50' - ATCOFLEX A-182-355
	056402-05-000	EA BRACKET-HEATER VENT, ROUND - W/BEND - BLACK
	077075-01-000	EA GASKET-INSTRUMENT PANEL TO DEFROSTER PLENUM, .6" X 11.3"
	077075-03-000	EA GASKET-INSTRUMENT PANEL TO DEFROSTER PLENUM, .6" X 10.2"
	103017-01-000	EA PLENUM-DEFROSTER
	103558-01-01A	EA VENT-DEFROSTER, ABS PLASTIC - OFF WHITE
	103796-01-01A	EA LOUVER ASM-A/C, 136.5 X 54.8MM - BLACK
	103930-05-000	EA MANUAL-OWNERS, HEATER-A/C - SCS 057-0049
	024990-05-000	EA OUTLET-DEFROSTER W/SWIVEL - 2" - BLACK
	008042-01-000	FT TUBING-VINYL, .65" ID

HEATING & AIR CONDITIONING GROUP (CONTINUED)

SUBURBAN FURNACE

KEY	PART NUMBER	U/M DESCRIPTION
	075697-04-000	EA FURNACE-FORCED AIR(19000BTU) NT-20S (2281)
	069634-01-706	EA MODULE-BOARD
	069634-01-709	EA ELBOW 90 BLK IRON
	069634-01-716	EA VALVE-MANUEL SHUT OFF
	069634-01-729	EA VALVE-GAS-JOHNSON
	069634-01-732	EA GASKET,BURNER ACCESS DOOR
	074035-01-706	EA WHEEL,COMBUSTION AIR
	074035-01-709	EA ORFICE
	074466-01-702	EA RELAY,TIME DELAY 205&L&45000
	075696-02-703	EA DUCT COLLAR
	075696-02-721	EA GASKET,GAS INLET PIPE
	075696-02-736	EA INTAKE TUBE ASSM
	075697-01-701	EA VENT CAP & EXHAUST ASM 20SE
	075697-01-704	EA CABINET, FRONT
	075697-04-700	EA SWITCH LIMIT
	075697-04-701	EA MOTOR
	075697-04-702	EA IMPELLER,ROOM AIR
	075697-04-703	EA ELECTRODE
	075697-04-704	EA DOOR,BURNER ACCESS
	092300-01-704	EA GASKET ELECTRODE
	093365-01-000	EA THERMOSTAT-FURNACE,SUBURBAN

CEILING ASSEMBLY - ROOF A/C

KEY	PART NUMBER	U/M DESCRIPTION
	108891-01-01A	EA CEILING ASM-A/C COOL TSR HO , COLEMAN 7330-714 IV
	042204-01-709	EA THERMOSTAT-IN 64 OUT 58, COLEMAN 6701-3401
	073742-01-701	EA SELECTOR SWITCH, 5 TERMINAL - COLEMAN 6759-3251
	073742-01-702	EA DECAL COOL ONLY, COLEMAN 6759C3431
	076303-01-707	EA FILTER - 6" X 14 3/4" X 1/2", 12 PER PKG, COLEMAN 6703A3151
	081606-01-712	EA CEILING SHROUD, IVORY - COLEMAN 6769-5061
	091225-01-713	EA KNOB, 2 PER PACKAGE - COLEMAN 6701-3351
	091225-01-717	EA DECAL, THERMOSTAT - COOL ONLY - COLEMAN 6799A3441
	093766-02-701	EA DECAL-LEFT SIDE, COLEMAN 6799-3971
	108891-01-700	EA SINGLE PARTS PACKAGE, KNOBS & NUTS - COLEMAN 6792-5991
	108891-01-701	EA RETAINER CLIPS FOR FILTER (6 PER), COLEMAN 6799-3141
	063903-01-702	EA LOUVER, COLEMAN 6703A5191

HEATING & AIR CONDITIONING GROUP (CONTINUED)

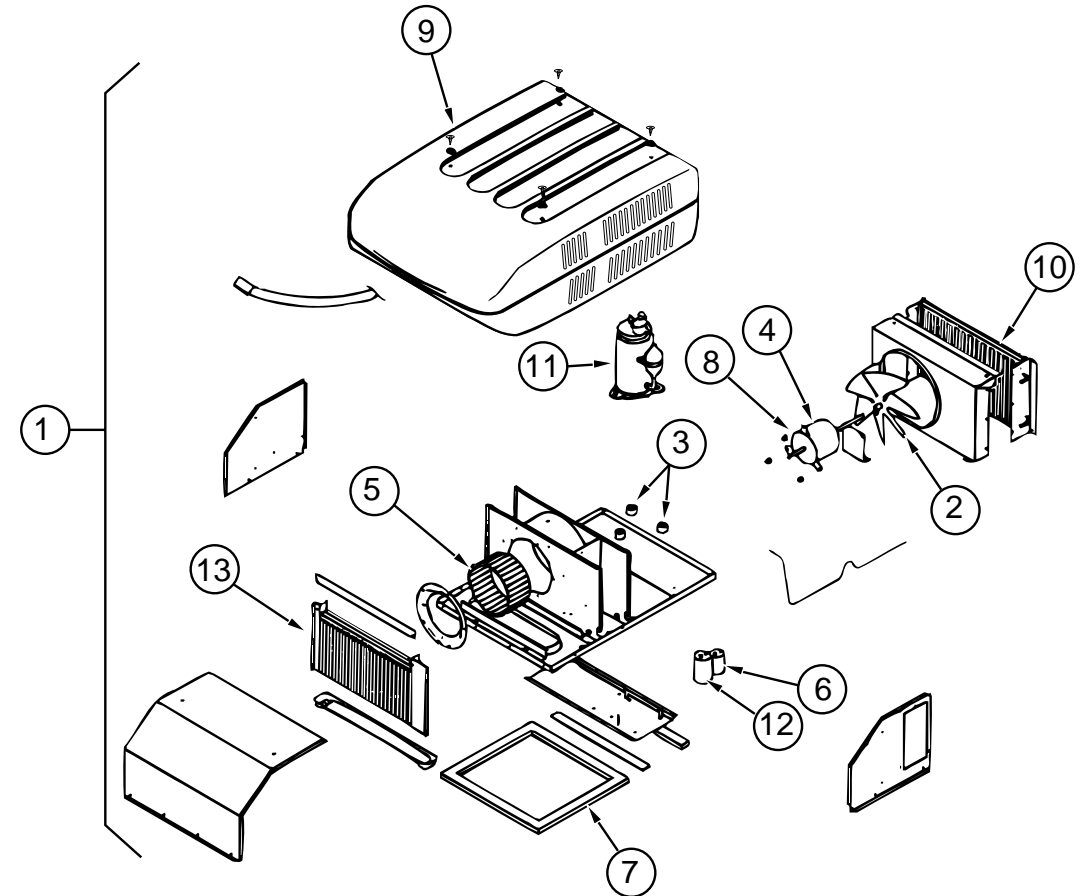

13,500 BTU COLEMAN ROOF A/C

KEY	PART NUMBER	U/M DESCRIPTION
1	108889-01-01A	EA A/C-ROOF, 13,500 TSR HO IVORY - COLEMAN 7333-887
2	093763-01-712	EA FAN BLADE-CONDENSER, COLEMAN 6733-3221
3	105620-01-706	EA FOOT PACKAGE-COMPRESSOR, 3 PER PACKAGE - COLEMAN 6759-3081
4	108889-01-705	EA MOTOR-115V, 60HZ - COLEMAN 1468-3049
5	108889-01-706	EA IMPELLOR - COLEMAN 1472-1041
6	108889-01-708	EA CAPACITOR-FAN, (7.5MFD.370U) - COLEMAN 1499-5461
7	108889-01-711	EA GASKET PACKAGE - COLEMAN 6792-3301
8	108889-01-715	EA MOTOR MOUNT & SHAFT SEAL KIT - COLEMAN 6792-3361
9	063903-01-700	EA SHROUD-(IVORY/IVORY), W/O LOGO - COLEMAN 6759-4601
10	108889-01-703	EA CONDENSER COIL - COLEMAN 1452-1301
11	105620-01-704	EA COMPRESSOR, RH & LH - COLEMAN 1450-2009
	108889-01-704	EA OVERLOAD - COLEMAN 6749-3541
12	108889-01-707	EA CAPACITOR-RUN, COMPRESSOR-25MFD/370 - COLEMAN 1499-5661
13	108889-01-709	EA EVAPORATOR COIL - COLEMAN 1452-1311
	091225-01-709	EA RELAY-START, COLEMAN 1497-4131
	091225-01-710	EA CAPACITOR-START, COLEMAN 1497-0881
	093306-01-701	EA DECAL PACKAGE-LEFT & RIGHT - COLEMAN 6798B3591
	108889-01-710	EA FILLER PAD-COND AIR SEAL - COLEMAN 6759A3971
	108889-01-712	EA REDUCER-SUCTION LINE, (3/8" X 1/2") - COLEMAN 1215-2161
	108889-01-713	EA SUCTION LINE, (3/8" OD X .032" WALL) - COLEMAN 6792-130
	108889-01-714	EA DISCHARGE LINE ASSEMBLY - COLEMAN 6792-531
	102289-01-000	EA SPRING-SCREW, ROOF A/C GASKET - COLEMAN 6757-150

INTERIOR FINISH GROUP

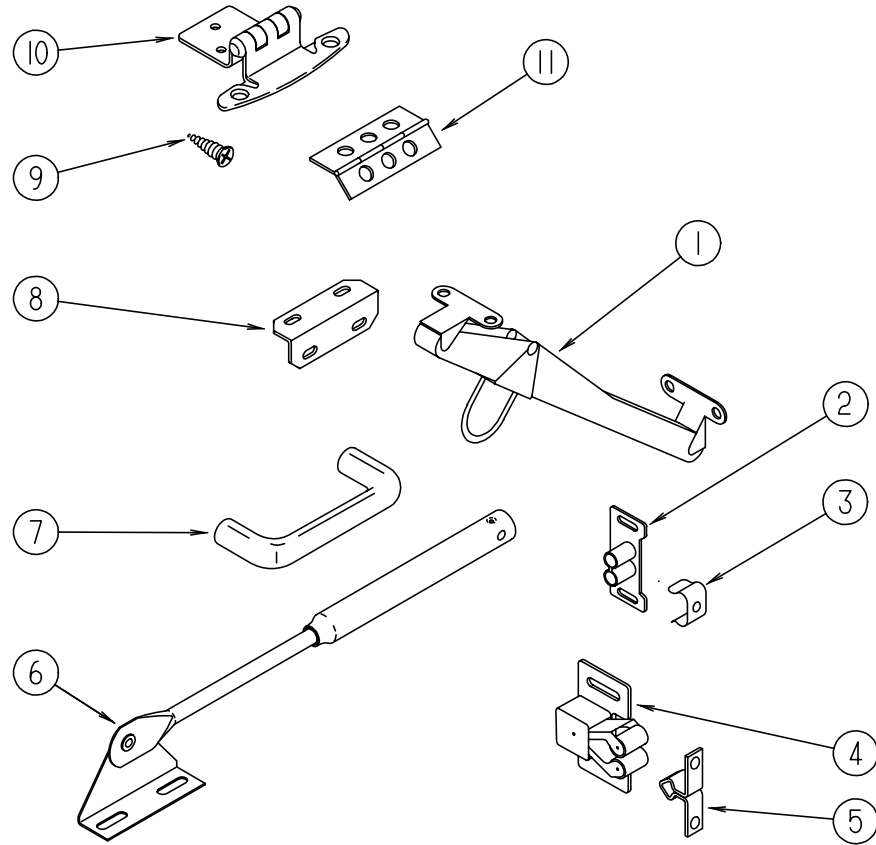

CABINET HARDWARE

KEY	PART NUMBER	U/M	DESCRIPTION
1	104181-01-01A	EA	SUPPORT-LEAF, 5.3" - EXTENDS TO 7.5" - SAFTY RING - METAL
2	009021-01-000	EA	CATCH-GRILLE, NYLON
3	009021-02-000	EA	STRIKE-SPRING STEEL
4	093586-03-000	EA	CATCH-SPRING, ROLLER
5	093586-04-000	EA	STRIKE-SPRING STEEL
6	074493-02-000	EA	SUPPORT-PISTON SPRING, CABINET DOOR
7	112146-01-000	EA	PULL-CABINET, BRASS - AMEROCK 1180-3
8	016604-01-000	EA	BRACE-CABINET, ANGLE - 2.5" - METAL - UNPAINTED
8	016604-03-000	EA	BRACE-CABINET, ANGLE - 2.5" - METAL - BEIGE
8	016604-05-000	EA	BRACE-CABINET, L ANGLE - 2.5" - METAL - OFF WHITE
9	000G13-06-08G	EA	SCREW, 6-20 X 1/2" PFH - ANTIQUE BRASS
10	108138-01-000	EA	HINGE-DOOR, CABINET - BURNISHED BRASS
11	009063-01-000	EA	HINGE-CONTINUOUS, 1 1/2" X 72" - UNPAINTED
11	009059-01-000	EA	HINGE-DOOR, 2" X 1.4" - BRASS
	076790-01-000	EA	SCREW, 6-20 X 1 1/4 PPH - BLACK
	004354-01-000	EA	BUMPER-RUBBER, .5" DIA - BROWN
	023320-01-000	EA	PAD-FELT, 3/8" DIAMETER - BROWN
	009112-01-000	EA	FLANGE-1" ROD, CLOTHES - PLASTIC - OFF WHITE
	042438-01-000	EA	DOWEL-WOOD, CLOTHES ROD - 1" DIAMETER X 4'
	000G13-06-10G	EA	SCREW-6-20 X 5/8 PFH, ANTIQUE BRASS
	084451-01-000	EA	CATCH-TV SHELF, BRASS

INTERIOR FINISH GROUP (CONTINUED)

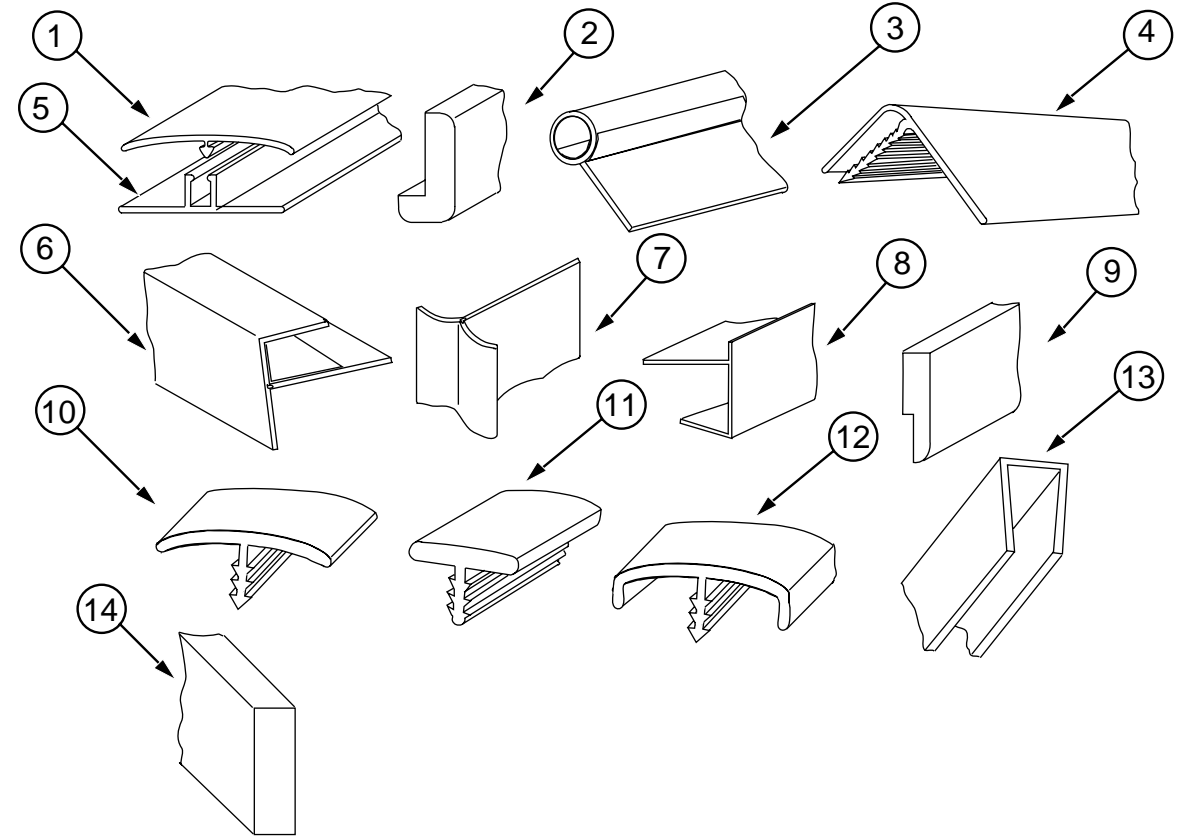

MOLDINGS, BATT STRIPS, & TRIM

KEY	PART NUMBER	U/M	DESCRIPTION
	085284-A5-000	FT	STRIP-TAPE,FRESCO,SILVERADO DECOR
	085284-A7-000	FT	STRIP-TAPE,TIGA BEND-PEARL DECOR
	085284-76-000	FT	BATT STRIP-SHOWER, ADHESIVE BACKED - OFF WHITE
	069733-80-000	EA	BATT STRIP-WOODGRAIN, 8' LONG - WINNI OAK
1	086229-04-000	EA	BATTEN-CEILING, 1" WIDE - IVORY - 7.6'
2	077840-01-E07	EA	MOLDING-WALL CAP, L SHAPED - WOOD
3	009767-10-000	FT	MOLDING-SIDEWALL TO CEILING/CABINET, WELTING - MAHOGANY
	009767-12-000	FT	MOLDING-SIDEWALL TO CEILING/CABINET, WELTING - OFF WHITE
4	009809-21-000	EA	MOLDING-CORNER, OUTSIDE - 1" - PLASTIC - WOODGRAIN
5	009812-22-000	EA	MOLDING-CORNER, OUTSIDE - .5" - PLASTIC - BROWN
	009812-24-000	EA	MOLDING-CORNER, OUTSIDE - .5" - PLASTIC - IVORY
6	022992-11-000	FT	MOLDING-REVERSE COVE, T-SHAPED - VINYL - IVORY
	076325-34-000	FT	MOLDING-EDGE BAND, 1 5/16" WIDE
7	103186-01-01A	FT	MOLDING-EDGE, SHELF - .78" WIDE - PLASTIC - RAMBLING OAK
8	105004-01-02A	EA	MOLDING-VINYL WRAP RAMBLING OAK
9	105709-01-000	FT	T-MOLDING-1", MODERN IVORY
10	104676-01-01A	FT	T-MOLDING, 5/16" RIGID - GOLD
10	104676-02-01A	FT	T-MOLDING, 1/2" RIGID - THOR PECAN
11	083620-07-000	FT	T-MOLDING, END CAP EDGE - W/EDGE LIPS - .75" - THOR PECAN
12	070504-19-000	FT	U-CHANNEL-PLASTIC, .815" WIDE - BROWN - INC. OF 8'
12	070504-26-000	FT	EXTRUSION-U CHANNEL,20.7 *MODERN IVORY
13	100040-01-000	EA	LUMBER-VINYL WRAPPED, .7" X 1.5" X 8' - RAMBLING OAK
13	100040-03-000	EA	LUMBER-VINYL WRAPPED, .71" X 2" X 8' - RAMBLING OAK

INTERIOR FINISH GROUP (CONTINUED)

PANELING, LAMINATES & PLASTIC

KEY	PART NUMBER	U/M	DESCRIPTION
	093743-02-01A	SF	PLASTIC-ABS, 20" WIDE ROLL - OFF WHITE
	074498-67-000	SF	LAMINATE-PLASTIC, ORCHID MIST (ALL)
	074497-19-000	SF	PANELING-CEILING, 4' X 8' - INCREMENTS OF 32 SF
	074497-21-000	SF	PANELING-WOODGRAIN, 4' X 8' - INCREMENTS OF 32 SF
	088272-98-000	SF	PANELING-SHOWER - OFF WHITE - 4' X 7' - INCREMENTS OF 28 SF
	088272-D7-000	SF	PANELING-FRESCO,SILVERADO
	089297-01-000	SF	PLYWOOD-LUAN - OVERLAY GRADE - 4' X 8' - INCREMENTS OF 32 SF
	095688-01-000	SF	VENEER-FLAT LUANA, 4' X 8'

DETECTORS & FIRE EXTINGUISHER

KEY	PART NUMBER	U/M	DESCRIPTION
	072852-01-000	EA	DETECTOR-SMOKE, W/9 VOLT BATTERY
	072852-02-000	EA	DETECTOR-SMOKE, W/9 VOLT BATTERY - CANADIAN
	094499-01-000	EA	EXTINGUISHER-FIRE, DRY W/MOUNTING BRACKET - 10 BC
	094499-01-700	EA	BRACKET-MOUNTING, W/PLASTIC STRAP - FIRE EXTINGUISHER
	112320-01-000	EA	DETECTOR-CO GAS, MODEL 9B-I - COSTAR 940000000
	112320-02-000	EA	BATTERY/SENSOR-CO GAS, COSTAR 940001000
	103613-01-000	EA	DETECTOR-LP GAS

FLOOR COVERINGS & MATS

KEY	PART NUMBER	U/M	DESCRIPTION
	096060-97-000	SY	CARPET-12' ROLL, INCREMENTS OF 4 SY - JUBILATION, LAPIS (FB1)
	096060-A1-000	SY	CARPET-12' ROLL, INCREMENTS OF 4 SY - JUBILATION,ARTIC GRAY (FC1)
	075233-01-000	SY	PAD-CARPET, 3/8" X 6' ROLL
	047034-02-000	SF	PLASTIC-CARPET, 4' WIDE - CLEAR POLY

LABELS GROUP

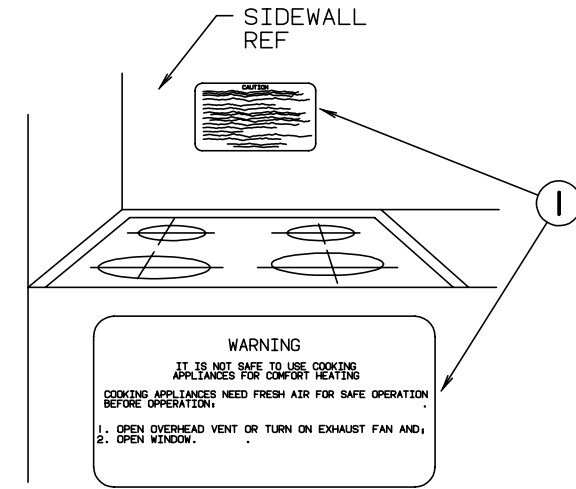

KEY	PART NUMBER	U/M	DESCRIPTION
1	050225-01-000	EA	LABEL-WARNING - STOVE VENT - US
1	050222-01-000	EA	LABEL-WARNING - STOVE VENT - CANADIAN

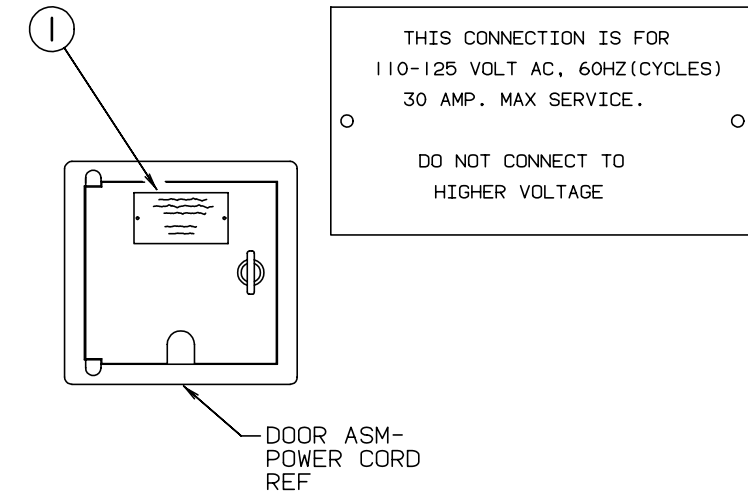

KEY	PART NUMBER	U/M	DESCRIPTION
1	006062-01-000	EA	TAG-ELECTRIC - 110V CONNECTION

MISCELLANEOUS LABELS

KEY	PART NUMBER	U/M	DESCRIPTION
	061606-01-000	EA	LABEL-OVERLAY - VEHICLE CERTIFICATION - ADHESIVE BACKED
	091243-01-000	EA	LABEL-A/C COVER - "AIR CONDITIONING CIRCUIT. ETC."
	098641-01-000	EA	LABEL-FUEL - UNLEADED - DASH
	106411-01-000	EA	LABEL-BUMPER OVERLOADING WARNING
	109522-01-000	EA	LABEL-BUMPER, SEE OWNERS MANUAL

LABELS GROUP (CONTINUED)

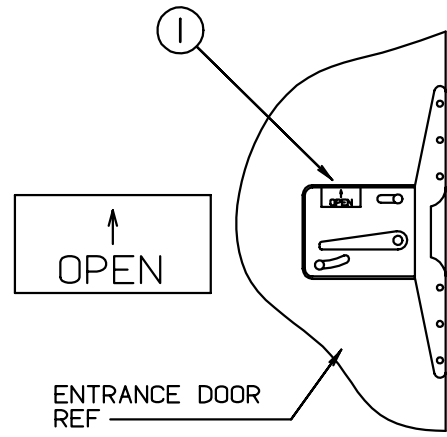

KEY	PART NUMBER	U/M DESCRIPTION
1	040944-01-000	EA LABEL-ENTRANCE DOOR - "OPEN"

LABELS GROUP (CONTINUED)

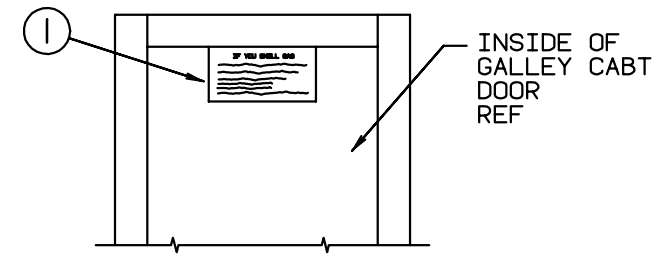

IF YOU SMELL GAS

1. EXTINGUISH ANY OPEN FLAME, PILOT LIGHTS AND ALL SMOKING MATERIALS.
2. SHUT OFF THE GAS SUPPLY AT THE TANK VALVE(OR GAS SUPPLY CONNECTION.
3. OPEN DOORS AND OTHER VENTILATING OPENINGS.
4. DO NOT TOUCH ELECTRICAL SWITCHES.
5. LEAVE THE AREA UNTIL ODOR CLEARS.
6. HAVE THE GAS SYSTEM CHECKED AND LEAKAGE SOURCE CORRECTED BEFORE USING AGAIN.

KEY	PART NUMBER	U/M DESCRIPTION
1	073998-01-000	EA LABEL-LPG ODOR WARNING

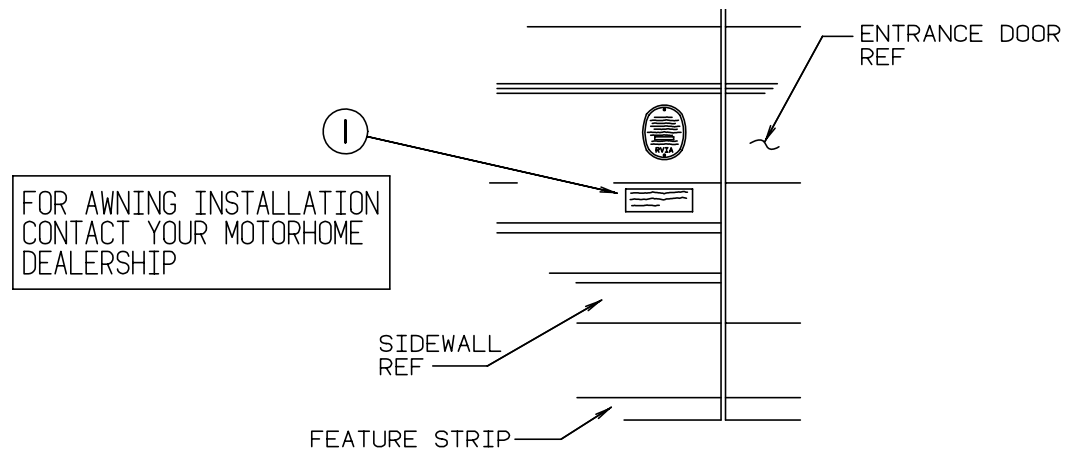

KEY	PART NUMBER	U/M DESCRIPTION
1	099509-01-000	EA LABEL-AWNING INSTALLATION

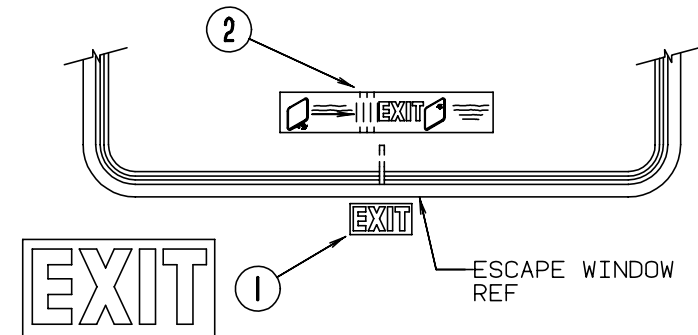
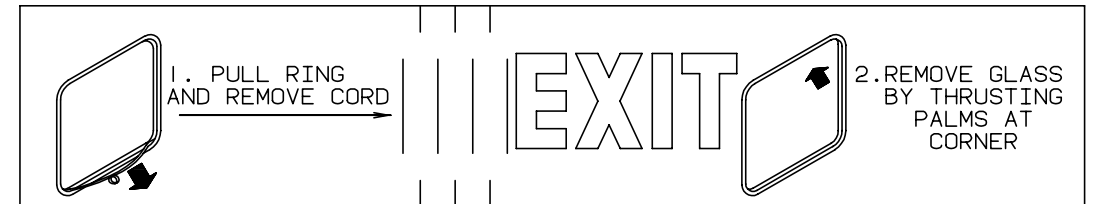

KEY	PART NUMBER	U/M DESCRIPTION
1	039290-01-000	EA LABEL-WARNING - EXIT
2	107571-01-000	EA LABEL-ESCAPE EXIT - WINDOW

LABELS GROUP (CONTINUED)

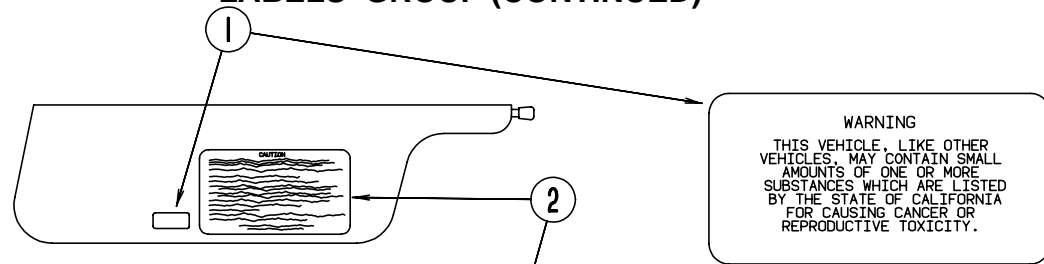

WARNING
 THIS VEHICLE, LIKE OTHER VEHICLES, MAY CONTAIN SMALL AMOUNTS OF ONE OR MORE SUBSTANCES WHICH ARE LISTED BY THE STATE OF CALIFORNIA FOR CAUSING CANCER OR REPRODUCTIVE TOXICITY.

CAUTION

THIS MOTOR HOME HAS BEEN DESIGNED, MANUFACTURED AND TESTED WITH CONCERN FOR THE PROTECTION OF IT'S OCCUPANTS. WE RECOMMEND YOU PERFORM THE FOLLOWING INSPECTIONS FOR YOUR SAFETY AND THE SAFETY OF YOUR PASSENGERS BEFORE STARTING YOUR VEHICLE.

1. LP GAS SYSTEM- TURN OFF AT TANK FOR TRAVELING. TEST FOR LEAKS UPON ARRIVAL AT DESTINATION. BEFORE LIGHTING PILOTS.
2. WHEELS- INSPECT FOR DAMAGE AND CHECK LUG NUTS FOR TIGHTNESS.
3. TIRES- INSPECT FOR WEAR AND DAMAGE AND CHECK FOR RECOMMENDED AIR PRESSURE.
4. LIGHTING- TEST FOR PROPER OPERATION OF ALL INTERIOR AND EXTERIOR LIGHTS INCLUDING DASH LIGHTS, HEADLIGHTS, TAIL LIGHTS, BRAKE LIGHTS, CLEARANCE LIGHTS AND TURN SIGNALS.
5. EXITS- INSPECT RELEASE MECHANISM ON EMERGENCY EXIT WINDOW. TEST BOTH LOCKS ON MAIN ENTRANCE DOOR FOR EASE OF OPERATION AND INSTRUCT PASSENGERS HOW TO USE BOTH MEANS OF EXIT.
6. SEAT BELTS- DIRECT PASSENGERS TO DESIGNATED SEATS AND REQUIRE USE OF SEAT BELTS.
7. APPLIANCES- TURN OFF AND LATCH OR LOCK DOORS WHERE PROVIDED.
8. LOOSE PARCELS- STORE SECURELY.
9. UTILITY SUPPLY LINES- DISCONNECT ALL ELECTRIC, SEWER AND WATER LINES AND SECURE PROPERLY.
10. ENTRANCE DOOR STEP- PLACE IN RETRACTED POSITION FOR TRAVELING.

READ YOUR MOTOR HOME AND CHASSIS OWNER'S MANUAL FOR FURTHER PRECAUTIONS

KEY	PART NUMBER	U/M DESCRIPTION
1	099689-01-000	EA LABEL-WARNING - CANCER/TOXICITY
2	056259-01-000	EA LABEL-SAFETY CHECK LIST

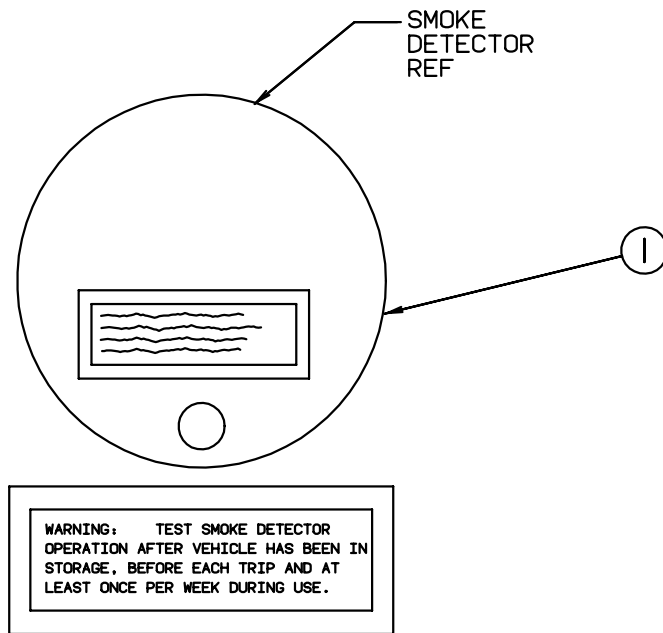

WARNING: TEST SMOKE DETECTOR OPERATION AFTER VEHICLE HAS BEEN IN STORAGE, BEFORE EACH TRIP AND AT LEAST ONCE PER WEEK DURING USE.

KEY	PART NUMBER	U/M DESCRIPTION
1	077956-01-000	EA LABEL-WARNING - SMOKE DETECTOR

LABELS GROUP (CONTINUED)

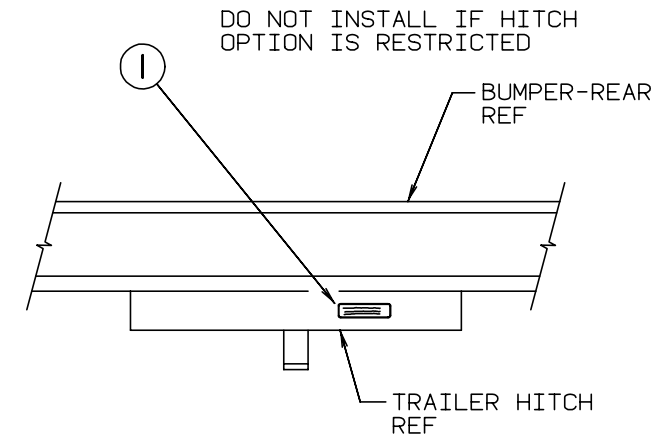

DO NOT USE HITCH BEFORE READING OWNERS MANUAL REGARDING VEHICLE LOADING AND TOWING

KEY	PART NUMBER	U/M DESCRIPTION
1	111104-01-000	EA LABEL-HITCH - READ MANUAL

WARNING DISCONNECT BATTERIES BEFORE CONNECTING EXTERNAL CHARGING EQUIPMENT.

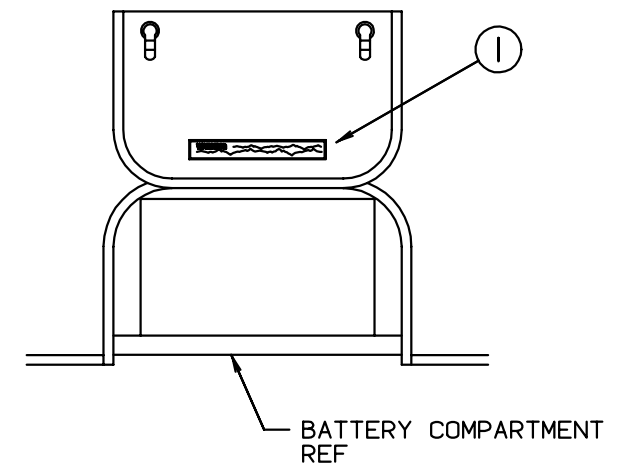

KEY	PART NUMBER	U/M DESCRIPTION
1	065748-01-000	EA LABEL-CAUTION - BATTERY CHARGING

LABELS GROUP (CONTINUED)

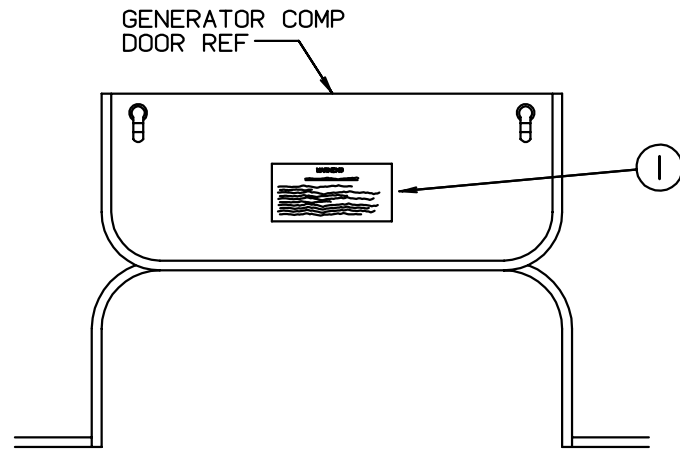

WARNING

WHEN ADDING A GENERATOR SET:

HIGH VOLTAGE-USE EXTREME CAUTION WHEN WORKING ON ELECTRICAL COMPONENTS.
 HAVE ALL ELECTRICAL INSTALLATION PERFORMED BY A QUALIFIED LICENSED ELECTRICIAN-FOLLOW ALL STATE AND LOCAL CODES.
 ONLY INSTALL GENERATOR SET APPROVED FOR R.V. APPLICATION. HAVE INSTALLED BY QUALIFIED TECHNICIAN.
 TO AVOID HEAT BUILD-UP AND TO GUARANTEE AN ADEQUATE AIR SUPPLY TO THE GENERATOR CARBURETOR, FOLLOW INSTALLATION INSTRUCTIONS.
 GENERATOR ENGINE EXHAUST GASES ARE TOXIC AND MUST NOT TERMINATE UNDER THE VEHICLE-DISCHARGE EXHAUST AWAY FROM VEHICLE.

KEY	PART NUMBER	U/M DESCRIPTION
1	077510-01-000	EA LABEL-GENERATOR PREP

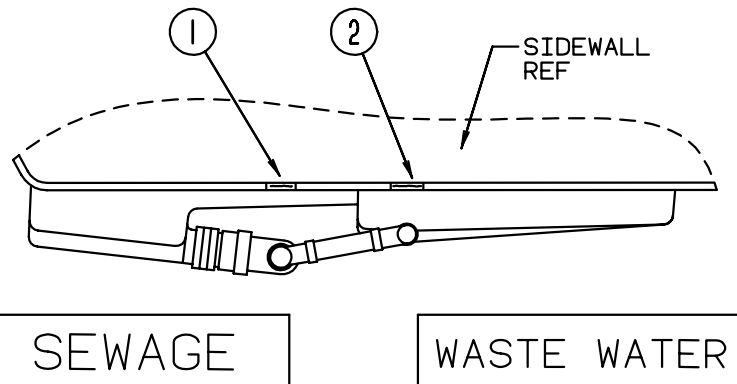

KEY	PART NUMBER	U/M DESCRIPTION
1	006187-01-000	EA LABEL-SEWAGE
2	006188-01-000	EA LABEL-WASTE WATER

LABELS GROUP (CONTINUED)

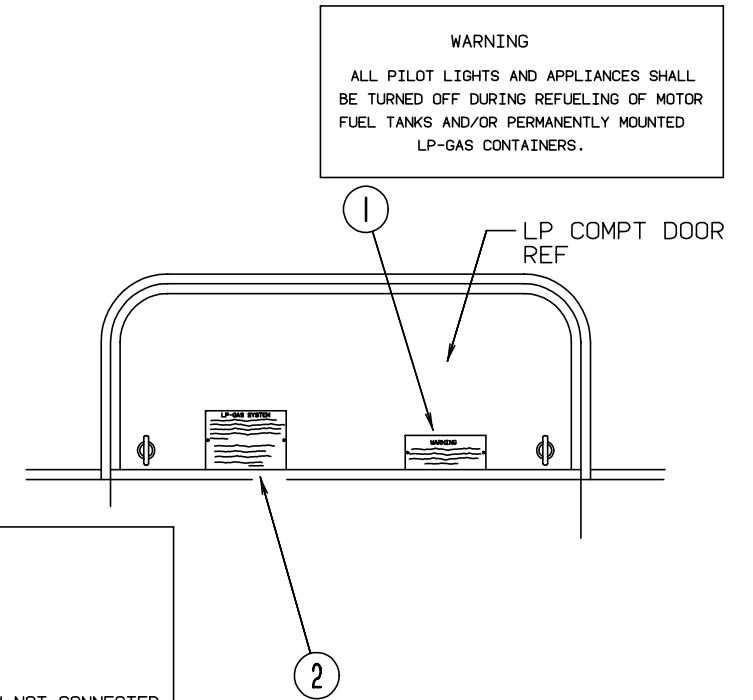

WARNING

ALL PILOT LIGHTS AND APPLIANCES SHALL BE TURNED OFF DURING REFUELING OF MOTOR FUEL TANKS AND/OR PERMANENTLY MOUNTED LP-GAS CONTAINERS.

LP-GAS SYSTEM

THIS GAS PIPING SYSTEM IS DESIGNED FOR USE OF LIQUEFIED PETROLEUM GAS ONLY. DO NOT CONNECT NATURAL GAS TO THIS SYSTEM.

SECURELY CAP INLET(S) WHEN NOT CONNECTED FOR USE. AFTER TURNING ON GAS, EXCEPT AFTER NORMAL CONTAINER REPLACEMENT, TEST GAS PIPING AND CONNECTIONS TO APPLIANCE FOR LEAKAGE WITH SOAPY WATER OR BUBBLE SOLUTION. DO NOT USE PRODUCTS THAT CONTAIN AMMONIA OR CHLORINE.
 P.N. 54531

KEY	PART NUMBER	U/M DESCRIPTION
1	006040-01-000	EA TAG-GAS REFUELING WARNING
1	006040-02-000	EA TAG-GAS REFUEL WARNING - CANADIAN
2	054531-01-000	EA LABEL-LP GAS ONLY
2	023769-01-000	EA LABEL-WARNING - LPG - CANADIAN

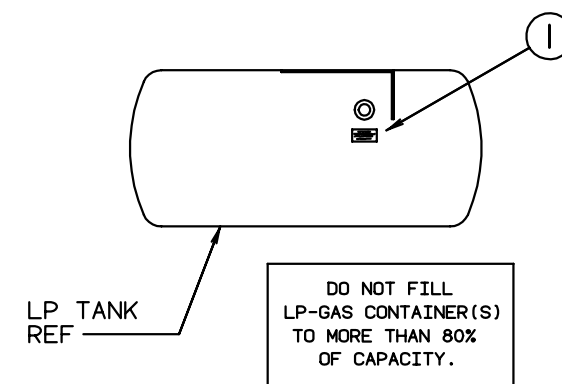

DO NOT FILL LP-GAS CONTAINER(S) TO MORE THAN 80% OF CAPACITY.

KEY	PART NUMBER	U/M DESCRIPTION
1	079965-01-000	EA LABEL-LPG 80% CAPACITY

LABELS GROUP (CONTINUED)

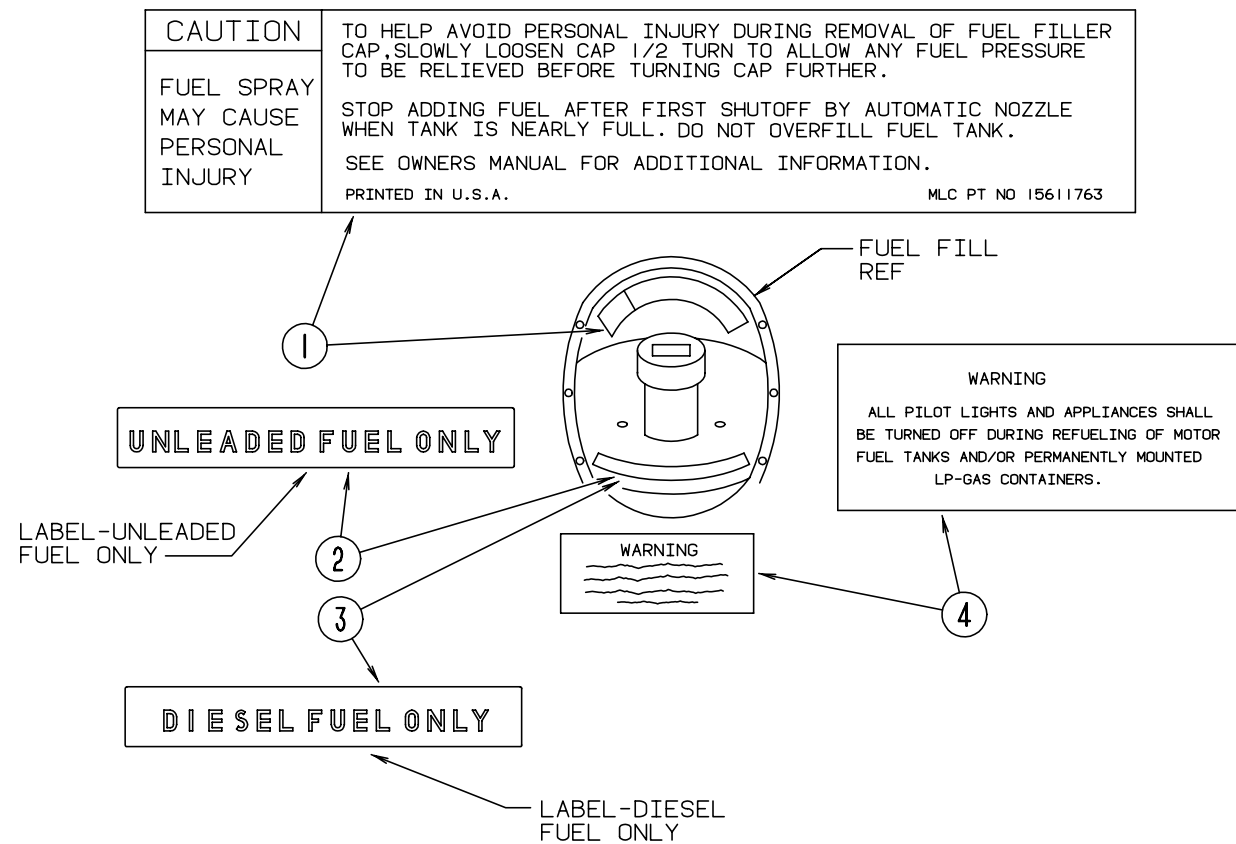

KEY	PART NUMBER	U/M	DESCRIPTION
1	087207-05-000	EA	LABEL-FUEL CAP REMOVAL - GM--15611763
2	062043-01-000	EA	LABEL-FUEL - UNLEADED
3	068383-01-000	EA	LABEL-DIESEL FUEL-GM----557005
4	006040-01-000	EA	TAG-GAS REFUELING WARNING
4	006040-02-000	EA	TAG-GAS REFUEL WARNING - CANADIAN

LP GROUP

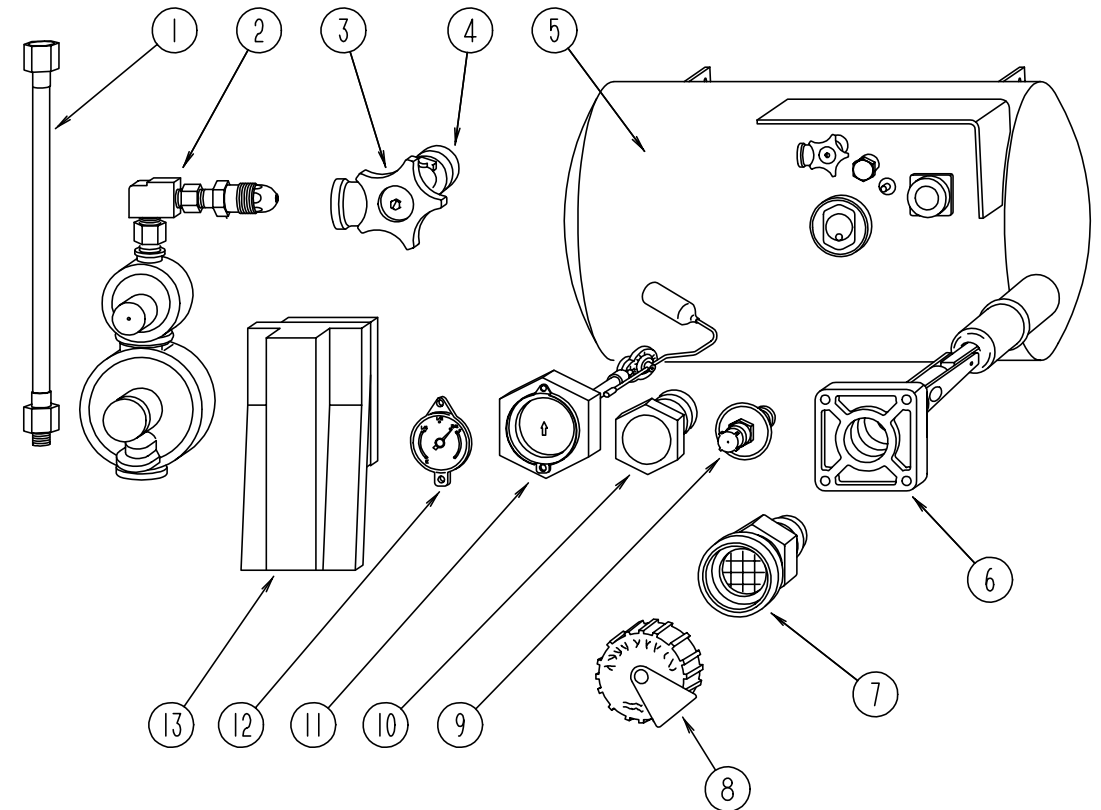

LP TANK & SYSTEM COMPONENTS

KEY	PART NUMBER	U/M	DESCRIPTION
1	045703-01-000	EA	HOSE-LP, 3/8" ID X 24" - 3/8 MPT X 1/2 F SWIVEL - U.S.
1	045703-02-000	EA	HOSE-LP, 3/8" ID X 24" - 3/8" MPT X 1/2" F SWIVEL - CANADA
2	106150-01-000	EA	REGULATOR-TWO STAGE, MARSHALL BRASS 293-00
3	040421-01-708	EA	HANDWHEEL-SERVICE VALVE, BRUNNER G-1015-A
4	040421-01-712	EA	VALVE-SERVICE W/O VAPOR RELIEF, 29000853
5	080450-01-000	EA	TANK-LP, 42LB - 13 DIA X 24 LONG
6	040421-01-711	EA	VALVE - 80% W/FLOAT, PLATE - BOLTS & GASKET - BRUNNER
7	040421-01-701	EA	VALVE-SHORT LP FILLER, W/YELLOW CAP - BRUNNER 75478
8	040421-01-702	EA	CAP-LP FILLER VALVE, PLASTIC - YELLOW - BRUNNER G-1014-A
9	040421-01-700	EA	VALVE-LIQUID LEVEL, 20% LP - BRUNNER G-1013
10	040421-01-713	EA	VALVE-VAPOR ONLY, 29000587
11	074142-01-700	EA	FLOAT GAUGE-SCREW ON-MACHINE 13C-SCR
12	040421-01-706	EA	DIAL-LP TANK VOLUME, VISIBLE FACE (5-1789) - BRUNNER MA-8 ROCHESTER
13	105658-01-000	EA	COMPARTMENT-LP REGULATOR
	010323-01-000	EA	ADAPTER-BRASS, 3/8F X 1/2MPT
	010377-02-000	EA	NUT-BRASS, 3/8 FEMALE - FORGED
	010380-02-000	EA	NUT-BRASS, 1/2 FEMALE - FORGED
	010329-01-000	EA	ADAPTER-BRASS, 1/2F X 1/2MPT
	010265-01-000	EA	ELBOW - 90 DEGREE, 3/8" F TO 1/2" FPT - BRASS
	065318-02-000	EA	ELBOW - 90 DEGREE, 3/8" MPT TO 3/8" FPT
	035340-01-000	EA	ELBOW, 3/8" MPT X 1/2" F - BRASS
	095624-01-000	EA	ELBOW - 90 DEGREE, 1/4" FPT X 1/4" FPT - BRASS
	103613-01-000	EA	DETECTOR-LP GAS
	071391-02-000	EA	NIPPLE-HEX, 1/4 PIPE - 3325 X 4 WEATHERHEAD

SEALANTS & FASTENERS GROUP

ADHESIVE AND FASTENERS

KEY	PART NUMBER	U/M DESCRIPTION
	062917-03-000	EA ADHESIVE-LOCTITE 242
	053766-08-000	EA BEDDING COMPOUND-TUBE - GRAY - SCHNEE# 5522
	087211-01-000	GL PROMOTER-ADHESIVE
	034552-02-000	EA SILICONE-TUBE - 300 ML - CLEAR
	034552-06-000	EA SILICONE-TUBE - 300 ML - OFF WHITE
	102352-01-000	EA SEALER-PUMPABLE - BLACK - COLORIMETRIC MS101
	069640-01-000	FT SEALER-RIBBON - 1/4" DIAMETER - INCREMENTS OF 30'
	069640-02-000	FT SEALER-RIBBON - 1/2" X 1/8" - INCREMENTS OF 30' OR 60'
	069640-03-000	FT SEALER-RIBBON - 3/4" X 1/8" - INCREMENTS OF 60'
	069640-07-000	FT SEALER-RIBBON - 2" X 3/32" - INCREMENTS OF 30' OR 45'
	069640-09-000	FT SEALER-RIBBON - 1/32" X 2 1/2" - INCREMENTS OF 80'
	069640-11-000	FT SEALER-TAPE - 3/16" X 3/8" - BLACK
	069640-14-000	FT SEALER-TAPE - 1/16" X 1" - GRAY
	110744-01-000	EA SEALANT-FOAM - POLYURETHANE
	072889-01-000	EA SEALANT-URETHANE - BLACK - 1/10 - ESSEX 552.2
	076314-02-000	FT TAPE-CARPET SEAM - HEAT-BOND - 4" WIDE
	076322-02-000	FT TAPE-FOAM - DOUBLE COATED ADHESIVE BACKED - 1" X 108'
	076322-05-000	FT TAPE-FOAM - DOUBLE COATED - .025" X 1.5" X 108'
	002707-02-000	FT TAPE-SEALER - 5/16" X 1/2" - INCREMENTS OF 50'
	900390-01-000	EA TIP - 2 1/2" X 1/8" ORIFICE - ELLSWORTH#TS216
	900390-02-000	EA TIP - 6"LN - 1/16" X 1/4" ORFICE - SEMCO#8607
	900390-03-000	EA NOZZLES-SILICONE TUBE - CSL# D10

BOLTS, NUTS & WASHERS

KEY	PART NUMBER	U/M DESCRIPTION
	051387-06-000	EA BOLT-CARRIAGE - W/O HOLE - 5/16-18 X 9.5 ZINC
	000C12-05-12B	EA BOLT-HEX - 5/16 - 18 X .75" - ZINC 5
	000C12-05-16B	EA BOLT-HEX - 5/16 - 18 X 1" - ZINC 5
	000C12-05-40B	EA BOLT-HEX - 5/16 - 18 X 2.5" - ZINC 5
	000C12-07-20B	EA BOLT-HEX - 7/16 - 14 X 1.25" - ZINC5
	000C12-08-24B	EA BOLT-HEX - 1/2 - 13 X 1.50" - ZINC 5
	000C13-07-48B	EA BOLT-HEX - 7/16 - 20 X 3" - ZINC 5
	000C13-07-24B	EA BOLT-HEX - 7/16 - 20 X 1 1/2" - GR 5
	000C13-07-48B	EA BOLT-HEX - 7/16 - 20 X 3" - ZINC 5
	000C26-04-10B	EA BOLT-HEX - SERRATED FLANGE - 1/4-20 X 5/8" - ZINC
	000C26-05-12B	EA BOLT-HEX - SERRATED FLANGE 5/16-18 X 3/4" - ZINC
	000C26-06-28B	EA BOLT-HEX - SERRATED FLANGE 3/8-16 X 1.75" - ZINC
	000D14-05-00B	EA NUT-HEX - 5/16-18 - ZINC 5
	000D24-10-00B	EA NUT-HEX - SELF LOCKING - 10-32 ZINC
	000D39-04-00B	EA NUT-HEX - SERRATED FLANGE LOCKING 1/4" - 20 - ZINC
	000D39-05-00B	EA NUT-HEX - SERRATED FLANGE LOCKING - 5/16" - 18 - ZINC
	000D39-06-00B	EA NUT-HEX - SERRATED FLANGE LOCKING - 3/8" - 16 - ZINC
	000D39-08-00B	EA NUT-HEX - SERRATED FLANGE LOCKING - 1/2" - 13 - ZINC
	000D44-07-00B	EA NUT-HEX - SERRATED FLANGE LOCKING - 7/16" - 20 - ZINC
	104369-01-000	EA NUT-HEX - HEAVY - 5/8" - 11 UNC - SPARE TIRE INSTL
	063253-07-000	EA NUT-J - #8A .120- .130 PNL THICK
	040921-04-000	EA NUT-SPEED - U TYPE - NO. 8 - .59" LENGTH X .44" WIDTH
	044364-02-000	EA NUT-SPEED - FLAT - ROUND
	044533-01-000	EA WASHER-PLASTIC - 1 3/8" OD - FOR BUTTONS
	000E11-07-00B	EA WASHER-LOCKING - 7/16" MEDIUM SPLIT - ZINC
	000E13-20-00B	EA WASHER-FLANGE - 7/16" WIDE - ZINC
	106649-01-000	EA WASHER-SEALING - GALVANIZED - 5/8" ID

SEALANTS & FASTENERS GROUP (CONTINUED)

SCREWS

KEY	PART NUMBER	U/M DESCRIPTION
	000G68-06-10G	EA SCREW - 6-18 X 5/8" POH - ANTIQUE BRASS
	000G12-06-08T	EA SCREW - 6-20 X .50" POH - BLACK
	000G13-06-08B	EA SCREW - 6-20 X .50" PFH - ZINC
	000G13-07-12B	EA SCREW - 7-19 X 3/4" PFH - ZINC
	000G11-08-06B	EA SCREW - 8-18 X 3/8" PPH - ZINC
	000G11-08-08B	EA SCREW - 8-18 X 1/2" PPH - ZINC
	000G11-08-12B	EA SCREW - 8-18 X 3/4" PPH - ZINC
	000G11-08-12D	EA SCREW - 8-18 X 3/4" PPH - BLACK
	000G11-08-12S	EA SCREW - 8-18 X 3/4" PPH - OFF WHITE
	000G11-08-12T	EA SCREW - 8-18 X 3/4" PPH - BLACK
	000G12-08-16S	EA SCREW - 8-18 X 1" POH - OFF WHITE
	000G13-08-10B	EA SCREW - 8-18 X 5/8" PFH - ZINC
	000G67-10-08B	EA SCREW - 10-12 X 1/2" PPH - ZINC
	000G67-10-10B	EA SCREW - 10-12 X 5/8" PPH - ZINC - TYPE A
	000G67-10-10R	EA SCREW - 10-12 X 5/8" PPH - TYPE A - BEIGE
	000G67-10-10S	EA SCREW - 10-12 X 5/8" PPH - OFF WHITE
	000G67-10-12B	EA SCREW - 10-12 X 3/4" PPH - ZINC
	000G67-10-120	EA SCREW - 10-12 X .75" PPH - TAN
	000G67-10-12P	EA SCREW - 10-12 X .75" PPH - DARK BROWN
	000G67-10-20D	EA SCREW - 10-12 X 1.25" PPH - BLACK
	000G67-10-36T	EA SCREW - 10-12 X 2.25" PPH - BLACK
	000G67-10-48B	EA SCREW - 10-12 X 3" PPH - ZINC
	000G57-10-16B	EA SCREW - 10-13 X 1" PFH - ZINC
	000G11-10-12S	EA SCREW - 10-16 X .75" PPH - OFF WHITE
	000G13-10-12B	EA SCREW - 10-16 X 3/4" PFH - ZINC
	000G11-10-40B	EA SCREW - 10-16 X 2.5" PPH - CAD
	000G36-10-12E	EA SCREW - 10-24 X 3/4" PFH - TYPE 23 - CHROME PLATED
	000G19-10-20B	EA SCREW-MACHINE - 10-32 X 1 1/4" - PPH - STAINLESS STEEL
	075908-01-000	EA SCREW-MACHINE - 10-32 X .56" PTH - ZINC EXTERNAL TOOTH
	000G50-04-12B	EA SCREW-MACHINE - 1/4-20 X 3/4" PPH - ZINC
	000G53-04-06B	EA SCREW-MACHINE - 1/4-20 X 3/8" PPH - ZINC - UNDERCUT HEAD
	000G39-06-08B	EA SCREW-DR - 6-18 X 1/2" - ZINC
	000G39-06-10T	EA SCREW-SF/DR - 6-20 X 5/8" PPH - BLACK
	000G39-08-08B	EA SCREW-SF/DR - 8-18 X .50" PPH - ZINC
	000G39-08-08R	EA SCREW-SF/DR - 8-18 X .50" PPH - BEIGE
	000G39-08-08S	EA SCREW-SF/DR - 8-18 X .50" PPH - OFF WHITE
	000G39-08-12B	EA SCREW-SF/DR - 8-18 X 3/4" PPH - ZINC
	000G39-08-16B	EA SCREW-SF/DR - 8-18 X 1" PPH - ZINC
	000G39-08-16T	EA SCREW-SF/DR - 8-18 X 1 PPH - BLACK
	000G39-10-12D	EA SCREW-SF/DR - 10-16 X 3/4" PPH - BLACK
	000G39-10-10B	EA SCREW-SF/DR - 10-16 X .625" PPH - ZINC
	000G60-10-28T	EA SCREW-SF/DR - 10-16 X 1.75" - BLACK
	000G42-04-16B	EA SCREW-SF/DR - 1/4-14 X 1" HWH - ZINC
	000G42-04-24B	EA SCREW-SF/DR - 1/4-14 X 1 1/2" - ZINC
	000G42-04-20B	EA SCREW-SF/DR - 1/4-14 X 1 1/4" - ZINC
	000G42-04-12B	EA SCREW-SF/DR - 1/4-14 X 3/4" HWH - ZINC
	000G54-04-20B	EA SCREW - 1/4-20 X 1 1/4 PTH - TYPE 23 - ZINC PLATED
	049465-01-000	EA SCREW - 10-16 W/WASHER PTH - DARK BROWN
	096526-01-000	EA SCREW-HEX - 1/4 - 28 UNF
	079382-01-000	EA SCREW-SOCKET - 8-18 X 1" - BLACK

SEALANTS & FASTENERS GROUP (CONTINUED)**CLAMPS, GROMMETS AND FASTENERS**

KEY	PART NUMBER	U/M	DESCRIPTION
	007125-03-000	EA	CLAMP-MUFFLER - 1.5" DIA
	007125-04-000	EA	CLAMP-MUFFLER - 1.1" DIA
	007161-01-000	EA	CLAMP-HOSE - SPRING TYPE - 1/2"
	010497-01-000	EA	CLAMP-CLOSED - 5/8" ID
	010497-03-000	EA	CLAMP-CLOSED - 1" ID - CUSHIONED
	010497-04-000	EA	CLAMP-CLOSED - 1.62 ID ADEL - 945-2717
	010497-05-000	EA	CLAMP-CLOSED - 1/2" ID
	010499-01-000	EA	CLAMP-CLOSED - 3/8" ID
	062401-01-000	EA	CLAMP-HOSE - WORMGEAR .25" - 1"
	062401-04-000	EA	CLAMP-HOSE - WORMGEAR .69" - 1.25"
	062401-06-000	EA	CLAMP-HOSE - WORMGEAR .22" - .62"
	062401-08-000	EA	CLAMP-HOSE - WORMGEAR 4.06" - 5.0"
	083609-01-000	EA	CLAMP-WIRE - DUAL EQUAL - 5/8" DIAMETER
	083610-01-000	EA	CLAMP-WIRE - DUAL - UNEQUAL DIAMETERS - .75" & 1.25"
	016188-05-000	EA	GROMMET-L/P LINE - 3/8" HOLE X 1 1/4" LONG - RUBBER
	061603-01-000	EA	GROMMET-SNAP - 3/16"ID - 3/8" HOLE - PLASTIC - BLACK
	023942-01-000	EA	GROMMET-RUBBER - 2" OD
	071015-11-000	EA	GROMMET-1.00" ID - FITS .12" MATERIAL - MINOR RUBBER Z-3065
	075148-02-000	EA	CLAMP-GROUNDING - BRONZE SCREWS
	077955-01-000	EA	CLIP-J - VINYL COATED - 3/8" - USED TO SUPPORT WIRING TO LIGHTS
	080734-02-000	EA	CLIP-WIRE - NYLON
	094362-02-000	EA	CLIP-CHRISTMAS TREE - FLAT HEAD - .5" X .95"
	029094-04-000	YD	VELCRO TAPE-LOOP - 1" WIDE - BLACK
	029094-03-000	YD	VELCRO TAPE-HOOK - 1" WIDE - BLACK
	081211-05-000	EA	PLUG-PLASTIC, .188 DIAMETER - NATURAL
	008343-01-000	EA	TIE-WIRE - 6"
	008343-02-000	EA	TIE-WIRE - 14"

WATER & SEWAGE GROUP**WATER HEATER**

KEY	PART NUMBER	U/M	DESCRIPTION
	051391-01-000	EA	HEATER-WATER - ATWOOD G6A-3
	051391-01-700	EA	HINGE KIT-W/CLIP - ATWOOD # 92568 & 92559
	051391-01-702	EA	TANK-INNER - G6A-2E, 3E, 6E - WATER HEATER - ATWOOD 91412
	051391-01-704	EA	VALVE-RELIEF - 1/2" FITTING - ATWOOD# 91604
	051391-01-705	EA	FASTENER-CAMLOC - ATWOOD# 92609
	051391-01-706	EA	GRILLE-EXHAUST - ATWOOD# 92787
	051391-01-708	EA	BURNER-MAIN - 3E ONLY - ATWOOD# 92615
	051391-01-709	EA	PILOT ASM-W/THERMOCOUPLE & TUBE - ATWOOD# 91603
	051391-01-710	EA	ORIFICE-MAIN BURNER - ATWOOD# 92742
	051391-01-711	EA	ELBOW-ORIFICE - MAIN BURNER - ATWOOD# 92741
	051391-01-712	EA	THERMOSTAT - 3/8" NPT INLET - ATWOOD# 91601
	051391-01-714	EA	ELBOW - 45 DEGREE - 3/8" F X 3/8" MPT - ATWOOD 91044
	051391-01-715	EA	DRAIN PLUG - ATWOOD# 91561

WATER & SEWAGE GROUP (CONTINUED)

WATER SYSTEM

KEY	PART NUMBER	U/M	DESCRIPTION
	101814-01-000	EA	COUPLING-FEMALE, 1/2" X 1/2" FPT W/COMP. SLEEVE - GRAY
	114430-02-000	EA	ADAPTER-SWIVEL, 1/2P X 1/2FPT FLAIR-IT -02873
	010219-01-000	EA	ELBOW-1 1/4" MPT X 1 1/4" BARB, WATER FILL - PLASTIC
	035539-01-000	EA	ELBOW-PLASTIC, 3/8"MPT X 3/8"BARB
	074462-02-000	FT	TUBING-VINYL, 3/8" ID - CLEAR
	077954-02-000	EA	FILTER-WATER TANK, SCREEN IN TANK
	079381-01-000	FT	TUBING-SMOOTH FLEXIBLE, 1 1/4" ID X 20'
	042989-03-000	EA	FITTING-WATER TANK, SPINWELD - 1 1/4"NPT - PLASTIC - WHITE
	042989-04-000	EA	FITTING-WATER TANK, SPINWELD - 3/8" FPT - PLASTIC - WHITE
	042989-05-000	EA	FITTING-WATER TANK, SPINWELD - 1/2" FPT - PLASTIC - WHITE
	049032-01-000	EA	PATCH-SPINWELD, 3/8" - PLASTIC
	109606-01-000	EA	TANK-WATER, 30 GAL
	114430-03-000	EA	ADAPTER - 1/2P X 1/2MPT FLAIR-IT 02842
	010230-05-000	EA	FILL-CITY-WATER,SURF. SILVER *M'BRASS 324-00
	039800-02-000	FT	TUBING-POLYBUTYL, 5/8" OD - INCREMENTS OF 20' - BLACK
	046128-01-000	EA	VALVE-DRAIN, PLASTIC - 1/2" FPT
	114428-01-000	EA	TEE - 1/2P X 1/2P X 1/2P FLAIR-IT 02820
	114428-03-000	EA	TEE - 1/2P X 1/2P X 1/2MPT FLAIR-IT 02822
	114429-01-000	EA	ELBOW-1/2P X 1/2P FLAIR-IT 02800
	114429-03-000	EA	ELBOW-SWIVEL, 1/2P X 1/2FPT FLAIR-IT 02816
	114430-02-000	EA	ADAPTER-SWIVEL, 1/2P X 1/2FPT FLAIR-IT -02873
	114431-01-000	EA	VALVE-LINE DRAIN 1/2P FLAIR-IT 02914
	114431-03-000	EA	VALVE-1/2P X 1.2P FLAIR-IT 02884

WATER PUMP

KEY	PART NUMBER	U/M	DESCRIPTION
	098607-01-000	EA	PUMP-WATER,FLOW 2.8 GPM,UL W/1/2MPT FITTING
	098607-02-000	EA	PUMP-WATER,FLOW 2.8 GPM,CSA W/1/2MPT FITTING
	098607-01-700	EA	PUMPHEAD-REPLACEMENT 94-236-08
	098607-01-701	EA	DRIVE ASSEMBLY 94-234-03
	098607-01-702	EA	DIAPHRAGM KIT 94-238-04
	098607-01-703	EA	VALVE ASSEMBLY 94-232-00
	098607-01-704	EA	HOUSING-UPPER 94-231-01
	098607-01-705	EA	CHECK VALVE KIT 94-237-00
	098607-01-706	EA	UPPER HOUSING/SWITCH KIT 94-231-20
	098607-01-707	EA	MOTOR/BASEPLATE REPLACEMENT 11-148-04

WATER TANK

KEY	PART NUMBER	U/M	DESCRIPTION
	112348-03-000	EA	TANK ASM-WATER - 54 GAL
	039861-01-000	EA	SENDING UNIT-W/SCREW - WASHER, WELL NUT, & TERMINAL RING
	049032-01-000	EA	PATCH-SPINWELD - 3/8" - PLASTIC
	042989-03-000	EA	FITTING-WATER TANK - SPINWELD - 1 1/4"NPT - PLASTIC - WHITE
	042989-04-000	EA	FITTING-WATER TANK - SPINWELD - 3/8" FPT - PLASTIC - WHITE
	042989-05-000	EA	FITTING-WATER TANK - SPINWELD - 1/2" FPT - PLASTIC - WHITE
	077954-02-000	EA	FILTER-WATER TANK - SCREEN IN TANK

WATER & SEWAGE GROUP (CONTINUED)

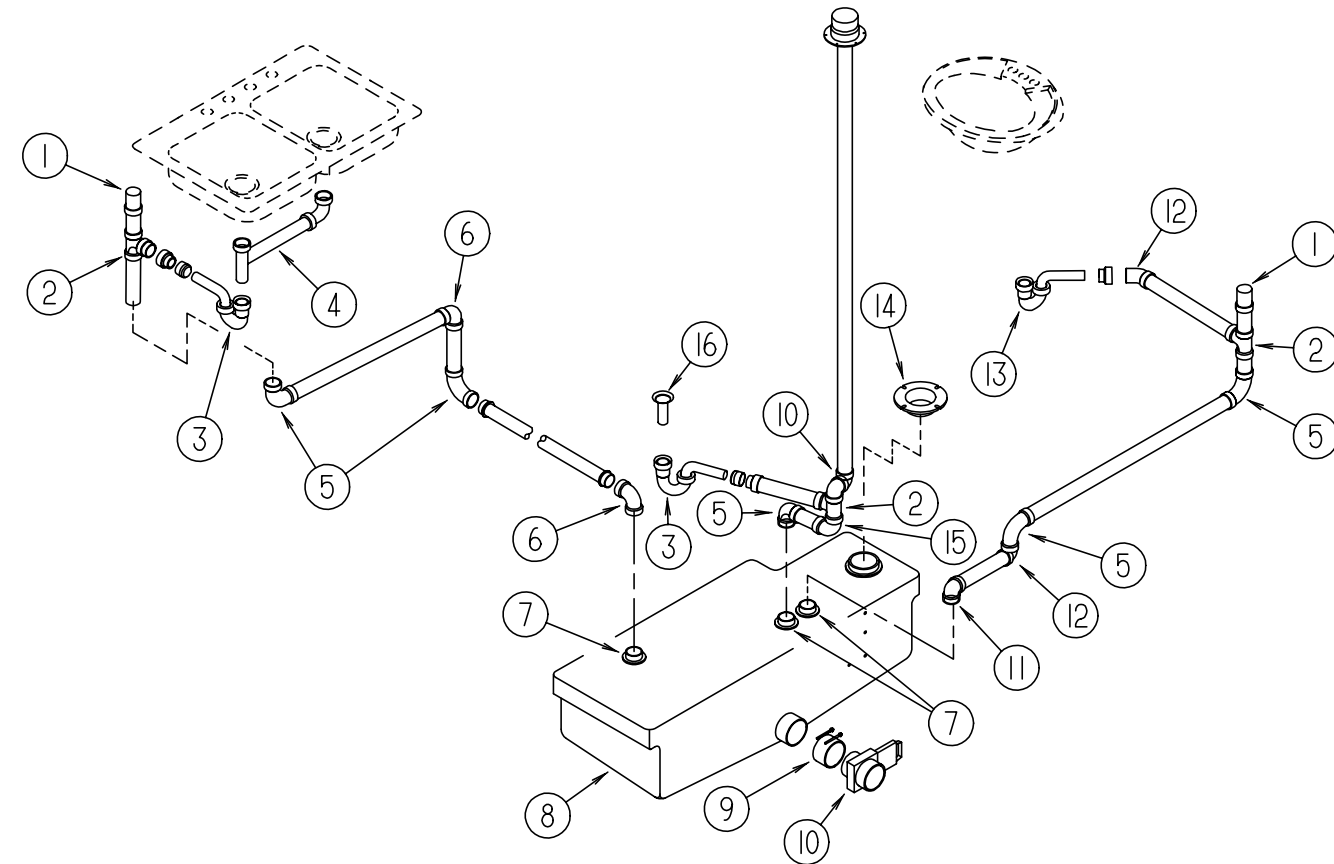

DRAINAGE SYSTEM

KEY	PART NUMBER	U/M	DESCRIPTION
	079968-01-000	EA	VENT-MECHANICAL TRAP ARM - ANTI-SIPHON - 2" DIA X 7.3" - PLASTIC
	010071-01-000	EA	TEE-SANITARY - 1 1/2" HUB X HUB X HUB - PLASTIC - BLACK
	107538-01-000	EA	P-TRAP-PLASTIC - 1 1/4" W/EXT ARM (US)
	011066-03-700	EA	P-TRAP - 1 1/2" TRAP X 1 1/4" SOCKET - PLASTIC (CSA)
	109571-01-000	EA	ADAPTER-P-TRAP - 1 1/2" P X 1 1/4" MPT (US)
	011091-03-000	EA	PIPE-DRAIN - W/SEALS - DOUBLE SINK - EXTENDS 9" TO 16"
	011091-02-000	EA	PIPE-DRAIN - DOUBLE SINK - BAFFLE TEE - 1 1/2"
	010008-01-000	EA	ELBOW - 90 DEGREE - 1/4 BEND - 1 1/2" HUB X HUB - BLACK PLASTIC
	034250-01-000	EA	ELBOW - 90 DEGREE - LONG TURN - 1 1/2" HUB X HUB - ABS
	061607-01-000	EA	GROMMET-HOLDING TANK - 1 1/2" NPS
	110508-01-000	EA	TANK-HOLDING - 38 GAL - BLANK
	078406-01-000	EA	COUPLER-RUBBER - W/CLAMPS - 3" X 3"
	062418-01-000	EA	VALVE-DUMP - W/HANDLE - 3" - PLASTIC - BLACK
	109450-01-000	EA	ADAPTER-PLAS HOSE - SEWER - KEVCO 40738
	062415-01-000	EA	CAP-SEWER - 3" DIAMETER
	062415-01-700	EA	STRING-SEWER CAP - SV7 STRAP
	010006-01-000	EA	ELBOW - 45 DEGREE - 1/8 BEND - 1 1/2" HUB X HUB - BLACK PLASTIC
	010051-01-000	EA	ELBOW - 45 DEGREE BEND - 1 1/2" SPIGOT AND HUB - PLASTIC - BLACK
	011069-02-000	EA	TAILPIECE-TUB/SHOWER - 1 1/2" X 1 1/4" X 4" - BRASS
	061607-02-000	EA	GROMMET-HOLDING TANK - 3" NPS
	033761-01-000	EA	ELBOW-TURN - 1/4 BEND X 1.5"HUB X 1.5"SPIGOT - BLK PLASTIC
	011069-02-000	EA	TAILPIECE-SHOWER/TUB - 1 1/2" X 1 3/4" - BRASS
	062422-01-000	EA	ADAPTER-OFFSET REDUCER - 3" X 1 1/2" - PLASTIC - BLACK
	010115-01-000	EA	COUPLING - 1 1/2" HUB X HUB - PLASTIC
	024676-01-000	EA	FLANGE-CLOSET - TOILET - 4" X 3" - RED
	024676-02-000	EA	FLANGE-CLOSET - 4" X 3" - ABS - CANADIAN

WINDOW, VENT & EXTERIOR DOOR GROUP

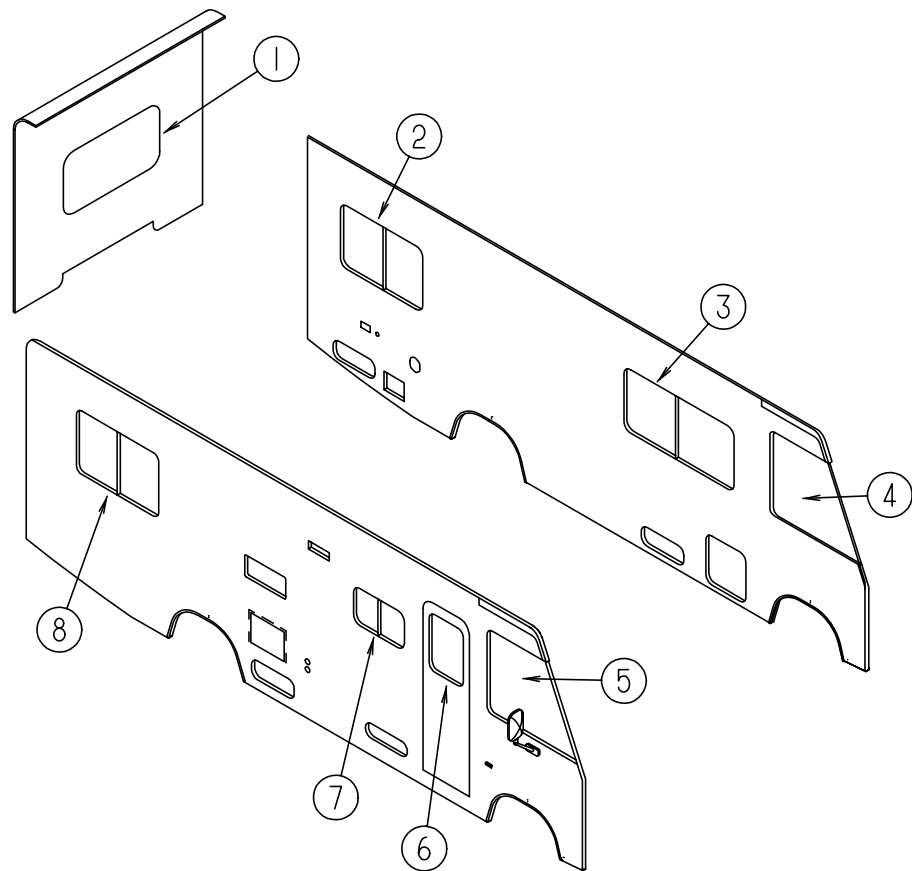

EXTERIOR WINDOWS

KEY	PART NUMBER	U/M	DESCRIPTION
1	078528-07-F15	EA	WINDOW-ESCAPE
1	074816-11-000	EA	FRAME-ESCAPE WINDOW - INSIDE - O/W
2	098647-30-01A	EA	WINDOW ASM-SLIDER - HORIZONTAL
3	098647-36-01A	EA	WINDOW ASM-SLIDER - HORIZONTAL
4	103658-09-01A	EA	WINDOW ASM-CAB - DRIVER
5	103658-10-01A	EA	WINDOW ASM-CAB - PASSENGER
6	079733-17-F15	EA	WINDOW-ENTRANCE DOOR - GLASS
	067609-38-000	EA	FRAME-WINDOW - ENTRY DOOR - OFF WHITE
7	098647-31-01A	EA	WINDOW-SLIDING - W/OFF WHITE INSIDE FRAME - EXCEL
8	098647-29-01A	EA	WINDOW ASM-SLIDER - HORIZONTAL

WINDOW, VENT & EXTERIOR DOOR GROUP (CONTINUED)

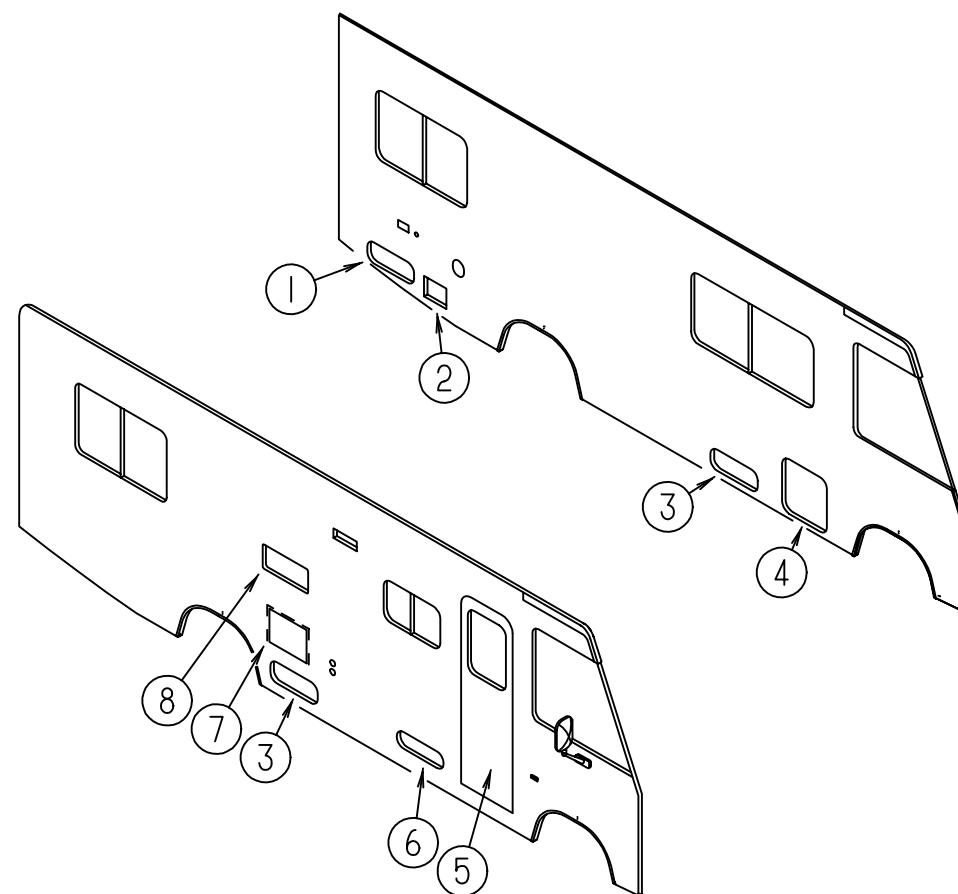

EXTERIOR DOORS & VENTS

KEY	PART NUMBER	U/M	DESCRIPTION
1	112009-01-EB1	EA	DOOR ASM-GENERATOR - OFF WHITE
1	112009-01-FB1	EA	DOOR ASM-GENERATOR - BRIGHT WHITE
2	088794-01-000	EA	DOOR-POWER CORD - W/HATCH - OFF WHITE
2	088794-06-000	EA	DOOR-POWER CORD - W/HATCH - BRIGHT WHITE
3	104558-08-DB1	EA	DOOR ASM-STORAGE - OFF WHITE
3	104558-08-FB1	EA	DOOR ASM-STORAGE - BRIGHT WHITE
4	104558-09-DB1	EA	DOOR ASM-STORAGE - OFF WHITE
4	104558-09-FB1	EA	DOOR ASM-STORAGE - BRIGHT WHITE
5	M06977-13-FB1	EA	DOOR-ENTRANCE W/O WINDOW - W/SCREEN - FLAT - OFF WHITE
5	M06977-14-FB1	EA	DOOR-ENTRANCE W/O WINDOW - W/SCREEN - FLAT - BRIGHT WHITE
6	111009-01-E01	EA	DOOR-COMPARTMENT - LP - 16.9" X 5.4" - ALUMINUM - OFF WHITE
6	111009-01-F24	EA	DOOR-COMPARTMENT - LP - 16.9" X 5.4" - ALUMINUM - BRIGHT WHITE
7	052009-01-000	EA	DOOR-WATER HEATER - OFF WHITE - ATWOOD 5576-27 - OFF WHITE
7	052009-06-000	EA	DOOR-WATER HEATER - OFF WHITE - ATWOOD 5576-27 - BRIGHT WHITE
8	084103-03-000	EA	DOOR-REFRIGERATOR - VENTED - W/O JAMB - OFF WHITE
8	084103-08-000	EA	DOOR-REFRIGERATOR - VENTED - W/O JAMB - BRIGHT WHITE
	084104-03-000	EA	JAMB-DOOR - REFRIGERATOR - OFF WHITE
	084104-08-000	EA	JAMB-DOOR - REFRIGERATOR - BRIGHT WHITE
	084104-01-700	EA	LOCK-MALE - FASTENER - REFRIGERATOR DOOR
	084104-01-701	EA	LOCK-FEMALE - FASTENER - REFRIGERATOR DOOR
	081240-11-000	EA	DOOR-WATER FILL - LOCKABLE - OFF WHITE
	081240-16-000	EA	DOOR-WATER FILL - LOCKABLE - BRIGHT WHITE
	103385-01-01A	EA	VENT-RANGE HOOD, OUTSIDE - OFF WHITE - VENTLINE
	103385-01-02A	EA	VENT-RANGE HOOD, OUTSIDE - BRIGHT WHITE - VENTLINE

WINDOW, VENT & EXTERIOR DOOR GROUP (CONTINUED)

LOCKS & COMPONENTS

NOTE:
WHEN ORDERING THE LOCK CASE, THE KEY CODE MUST MATCH THE LAST DIGIT OF THE UNIT'S SERIAL NUMBER AND PART NUMBER; WHEN ORDERING THE KEYS, THE THIRD DIGIT OF THE KEY CODE MUST MATCH THE LAST DIGIT OF THE UNIT'S SERIAL NUMBER AND PART NUMBER.

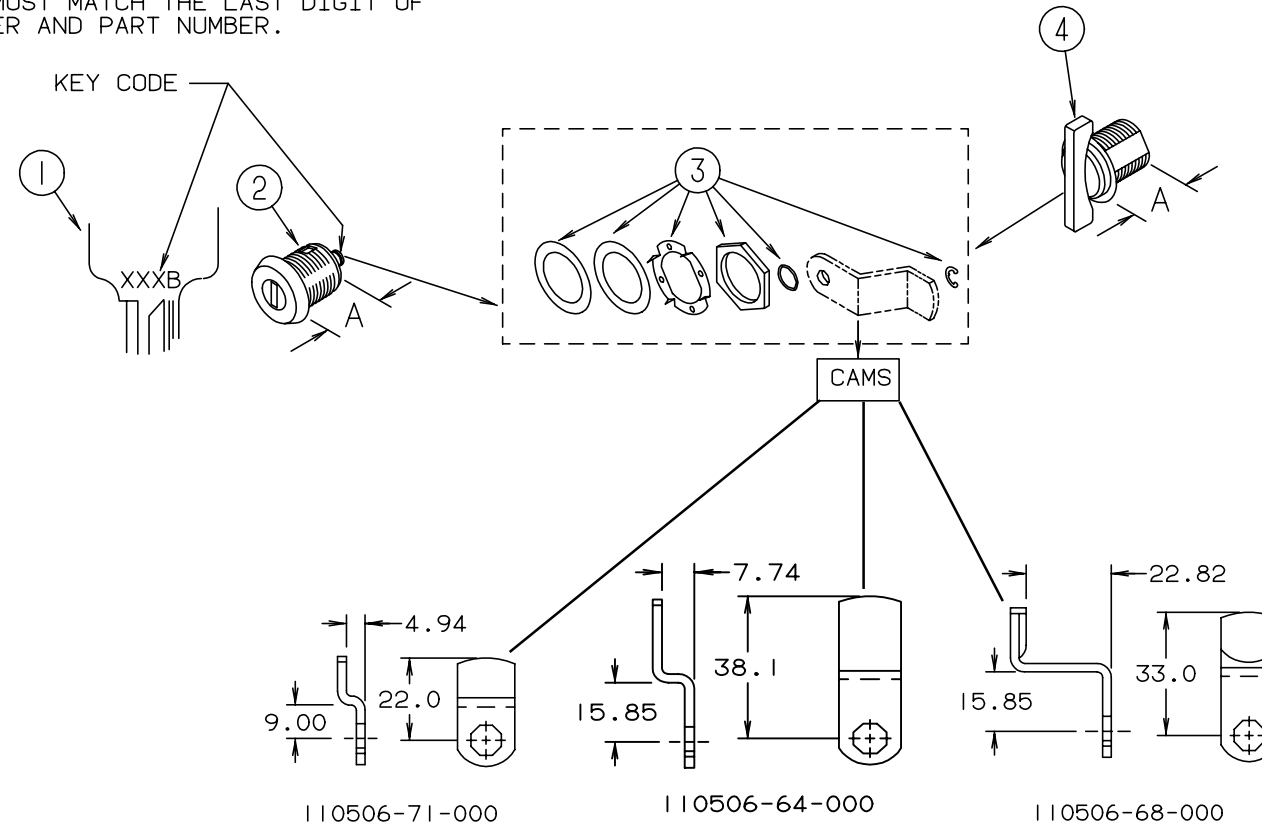

KEY	PART NUMBER	U/M	DESCRIPTION
1	110506-59-000	EA	KEYS - SET OF TWO - BRIGGS & STRATTON 596720 (SERIAL # ENDS IN 0)
2	110506-52-000	EA	CASE - LOCK - A= 17 MM - BRIGGS & STRATTON 702370 (KEY CODE # 0)
2	110506-53-000	EA	CASE - LOCK - A= 25 MM - BRIGGS & STRATTON 702380 (KEY CODE # 0)
1	110506-59-001	EA	KEYS - SET OF TWO - BRIGGS & STRATTON 596721 (SERIAL # ENDS IN 1)
2	110506-52-001	EA	CASE - LOCK - A= 17 MM - BRIGGS & STRATTON 702371 (KEY CODE # 1)
2	110506-53-001	EA	CASE - LOCK - A= 25 MM - BRIGGS & STRATTON 702381 (KEY CODE # 1)
1	110506-59-002	EA	KEYS - SET OF TWO - BRIGGS & STRATTON 596722 (SERIAL # ENDS IN 2)
2	110506-52-002	EA	CASE - LOCK - A= 17 MM - BRIGGS & STRATTON 702372 (KEY CODE # 2)
2	110506-53-002	EA	CASE - LOCK - A= 25 MM - BRIGGS & STRATTON 702382 (KEY CODE # 2)
1	110506-59-003	EA	KEYS - SET OF TWO - BRIGGS & STRATTON 596723 (SERIAL # ENDS IN 3)
2	110506-52-003	EA	CASE - LOCK - A= 17 MM - BRIGGS & STRATTON 702373 (KEY CODE # 3)
2	110506-53-003	EA	CASE - LOCK - A= 25 MM - BRIGGS & STRATTON 702383 (KEY CODE # 3)
1	110506-59-004	EA	KEYS - SET OF TWO - BRIGGS & STRATTON 596724 (SERIAL # ENDS IN 4)
2	110506-52-004	EA	CASE - LOCK - A= 17 MM - BRIGGS & STRATTON 702374 (KEY CODE # 4)
2	110506-53-004	EA	CASE - LOCK - A= 25 MM - BRIGGS & STRATTON 702384 (KEY CODE # 4)
1	110506-59-005	EA	KEYS - SET OF TWO - BRIGGS & STRATTON 596725 (SERIAL # ENDS IN 5)
2	110506-52-005	EA	CASE - LOCK - A= 17 MM - BRIGGS & STRATTON 702375 (KEY CODE # 5)
2	110506-53-005	EA	CASE - LOCK - A= 25 MM - BRIGGS & STRATTON 702385 (KEY CODE # 5)
1	110506-59-006	EA	KEYS - SET OF TWO - BRIGGS & STRATTON 596726 (SERIAL # ENDS IN 6)
2	110506-52-006	EA	CASE - LOCK - A= 17 MM - BRIGGS & STRATTON 702376 (KEY CODE # 6)
2	110506-53-006	EA	CASE - LOCK - A= 25 MM - BRIGGS & STRATTON 702386 (KEY CODE # 6)

KEY	PART NUMBER	U/M	DESCRIPTION
1	110506-59-007	EA	KEYS - SET OF TWO - BRIGGS & STRATTON 596727 (SERIAL # ENDS IN 7)
2	110506-52-007	EA	CASE - LOCK - A= 17 MM - BRIGGS & STRATTON 702377 (KEY CODE # 7)
2	110506-53-007	EA	CASE - LOCK - A= 25 MM - BRIGGS & STRATTON 702387 (KEY CODE # 7)
1	110506-59-008	EA	KEYS - SET OF TWO - BRIGGS & STRATTON 596728 (SERIAL # ENDS IN 8)
2	110506-52-008	EA	CASE - LOCK - A= 17 MM - BRIGGS & STRATTON 702378 (KEY CODE # 8)
2	110506-53-008	EA	CASE - LOCK - A= 25 MM - BRIGGS & STRATTON 702388 (KEY CODE # 8)
1	110506-59-009	EA	KEYS - SET OF TWO - BRIGGS & STRATTON 596729 (SERIAL # ENDS IN 9)
2	110506-52-009	EA	CASE - LOCK - A= 17 MM - BRIGGS & STRATTON 702379 (KEY CODE # 9)
2	110506-53-009	EA	CASE - LOCK - A= 25 MM - BRIGGS & STRATTON 702389 (KEY CODE # 9)
3	110506-40-700	EA	HARDWARE KIT
4	110506-50-000	EA	CASE - TWIST LOCK - A= 17 MM - BRIGGS & STRATTON 596952
4	110506-51-000	EA	CASE - TWIST LOCK - A= 25 MM - BRIGGS & STRATTON 596669
	110506-40-000	EA	CLIP-E - LOCK ASM. - BRIGGS & STRATTON 93981
	110506-64-000	EA	CAM - LOCK - BRIGGS & STRATTON 322280
	110506-67-000	EA	CAM - LOCK - BRIGGS & STRATTON 322283
	110506-71-000	EA	CAM - LOCK - BRIGGS & STRATTON 322287
	110506-72-000	EA	CAM - LOCK - BRIGGS & STRATTON 322354
	110506-59-701	EA	KEY BLANK - GOLD

WINDOW, VENT & EXTERIOR DOOR GROUP (CONTINUED)

ENTRANCE DOOR

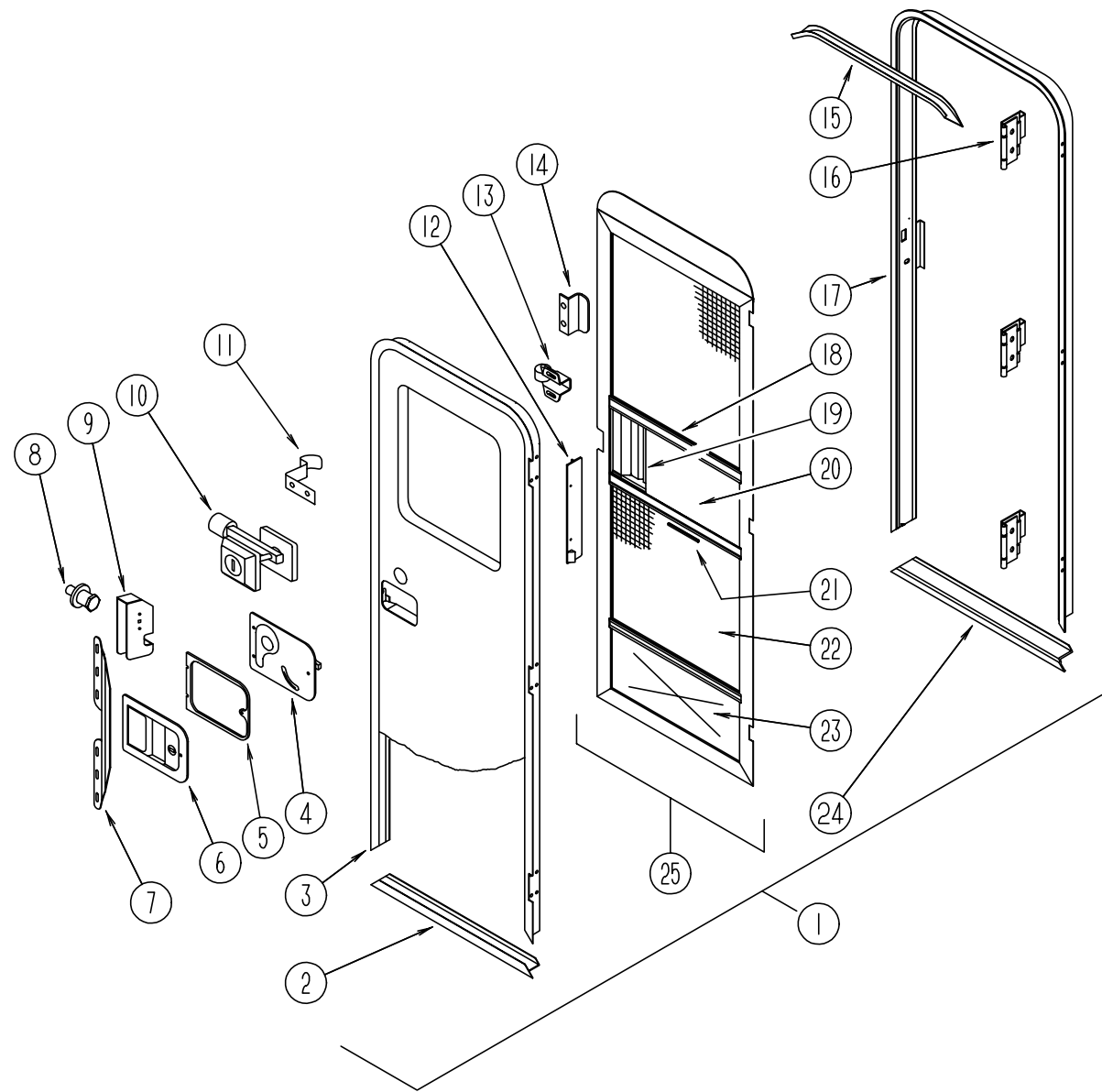

KEY	PART NUMBER	U/M	DESCRIPTION
1	115108-03-EB1	EA	DOOR-ENTRANCE, W/O WINDOW & SCREEN - FLAT - OFF WHITE
1	115108-03-FB1	EA	DOOR-ENTRANCE, W/O WINDOW & SCREEN - FLAT - BRIGHT WHITE
2	089748-05-000	EA	FRAME-DOOR, ENTRANCE - BOTTOM - BRIGHT WHITE
2	089748-21-000	EA	FRAME-DOOR, ENTRANCE - BOTTOM - OFF WHITE
	090340-01-000	FT	SEAL-FOAM, CLOSED CELL - 1/4" X 1/2" X 50'
3	095276-02-01A	EA	FRAME-DOOR, ENTRANCE - TOP & SIDES - OFF WHITE
3	095276-01-05A	EA	FRAME-DOOR, ENTRANCE - TOP & SIDES - BRIGHT WHITE
4	039979-04-000	EA	COVER-INTERIOR LATCH, W/TRIP ARM - RIGHT - BLACK
	039984-01-000	EA	CAP-ROUND, VINYL - .28" ID X .62" LONG - BLACK
	041546-03-000	EA	BRACKET-DOOR ANGLE, 5" X 1.9" - BEIGE - METAL
	041546-05-000	EA	BRACKET-DOOR ANGLE, 5" X 1.9" - BRIGHT WHITE - METAL
5	096810-01-01A	EA	PLATE-LATCH, ENTRANCE DOOR - PLASTIC - BLACK
6	045017-11-000	EA	LATCH-ENTRANCE DOOR, MECHANISM W/LOCK & KEY - BLACK
	045017-11-701	EA	KEY-BLANK
	058025-02-000	EA	CLIP-ROLLER LATCH CATCH, SCREEN DOOR
	063729-04-000	EA	RIVNUT, 10-32 UNF - .010-.080
	075671-04-000	FT	SEAL-SPONGE, LAZY T SHAPE - W/ADHESIVE STRIPE - .5" WIDE
7	098173-01-04A	EA	STIFFENER-ENTRANCE DOOR, SUPPORTS LATCH/STRIKE AREA - OFF WHITE
7	098173-01-07A	EA	STIFFENER-ENTRANCE DOOR, SUPPORTS LATCH/STRIKE AREA - BRIGHT WHITE
	100128-02-000	FT	SEAL-PILE, ADHESIVE BACK - SCREEN DOOR - GRAY
8	039539-01-000	EA	STRIKE-LOCK, ENTRY DOOR - ROUND W/THREADED WASHER
9	039540-01-000	EA	LATCH MECHANISM-HOOK, ENTRY DOOR - INTERIOR
	039715-01-000	EA	NUT-SERT, 1/4" DIAMETER - 20 THREADS
10	101145-01-01A	EA	DEADBOLT-ENTRANCE DOOR, W/2 KEYS W/O BACK SET BOLT OR SCREWS
	095229-01-700	EA	KEY BLANK
	101147-01-000	EA	BOLT-SECURITY, 4.12" BACKSET
	058806-01-000	EA	PLUG-TAPERED, FOR DEADBOLT - PLASTIC - .94" DIAMETER - RED
	102524-01-000	EA	BUMPER-RUBBER, FLAT - BLACK
11	100412-01-000	EA	CATCH-SCREEN DOOR, THUMB CLIP W/BLACK PLASTIC CAP
	056746-01-000	EA	PLUG-CAP, 1" DIAMETER
	039984-01-000	EA	CAP-ROUND, VINYL - .28" ID X .62" LONG - BLACK
	102768-01-000	EA	HOLDER-ENTRY DOOR, METAL - MILL FINISH
12	079087-02-000	EA	STRIKE-SLIDER, W/LIP FOR ELBOW CATCH - 1.5" X 8.6" - OFF WHITE
13	100412-01-000	EA	CATCH-SCREEN DOOR
14	050712-04-000	EA	HANDLE-SCREEN DOOR, ALUMINUM - OFF WHITE
15	044582-02-000	EA	CAP-DRIP, DOOR JAMB MOUNTED - OFF WHITE
15	044582-44-000	EA	CAP-DRIP, DOOR JAMB MOUNTED - BRIGHT WHITE
	115222-06-01A	EA	GARNISH-RADIUS, ENTRANCE DOOR - OFF WHITE
	077461-03-000	EA	COVER-STRIKE, ENTRANCE DOOR - 6.5" X 2.5" - PLASTIC - WHITE
	077461-06-000	EA	COVER-STRIKE, ENTRANCE DOOR - 6.5" X 2.5" - PLASTIC - BRIGHT WHITE
	090340-01-000	FT	SEAL-FOAM, CLOSED CELL - 1/4" X 1/2" X 50'
	091876-01-000	EA	RETAINER-DOOR, 1.9" X .8" - METAL
16	106719-01-01A	EA	HINGE-ENTRANCE DOOR, UNPAINTED
	102248-01-000	EA	SHIM-DOOR
17	095277-03-01A	EA	JAMB-ENTRANCE DOOR, OFF WHITE
17	095277-02-05A	EA	JAMB-ENTRANCE DOOR, BRIGHT WHITE
18	078777-01-000	EA	CHANNEL-SLIDE, SCREEN DOOR CENTER SLIDER COVER - 17.4"
19	079086-02-000	EA	SLIDER-SCREEN DOOR, OFF WHITE
20	001014-01-013	EA	INSERT-CENTER, 10.25" X 16.31" - UNPAINTED
21	002294-01-000	FT	SPLINE-SCREENING, .135" X .138" - BLACK
	002748-01-000	EA	CORNER KEY-DOOR
22	002293-02-000	SF	SCREENING-WINDOW & DOOR, 26" - CHARCOAL
23	078552-03-000	EA	INSERT-SCREEN DOOR, LOWER - UNPAINTED
	078595-01-000	EA	PLATE-SCREEN DOOR
24	051049-01-000	EA	JAMB-ENTRANCE DOOR, BOTTOM - UNPAINTED
25	079012-01-U01	EA	DOOR-SCREEN - OFF WHITE
25	079012-01-FB1	EA	DOOR-SCREEN - BRIGHT WHITE

WINDOW, VENT & EXTERIOR DOOR GROUP (CONTINUED)**POWERED ROOF VENT**

KEY	PART NUMBER	U/M	DESCRIPTION
	110051-03-01A	EA	VENT-ROOF, POWERED - 2" ROOF - US - JENSEN C7757 WHEAT
	110051-05-01A	EA	VENT-ROOF, POWERED - 2" ROOF - CSA - JENSEN C7757 WHEAT
	048648-01-000	EA	MOTOR-ROOF VENT, 1/8 SHAFT - 12V - JENSEN
	048649-01-000	EA	FAN-ROOF VENT, 6 BLADES - 6" - JENSEN
	064470-01-700	EA	COVER ROOF VENT, 7291
	110051-01-700	EA	SCREEN-ROOF VENT
	110051-01-701	EA	GARNISH W/SCREEN & FRAME 2"
	110051-01-702	EA	HAND CRANK & OPERATOR ASM.
	110051-01-703	EA	HANDLE CRANK

NONPOWERED ROOF VENT

KEY	PART NUMBER	U/M	DESCRIPTION
	110051-01-01A	EA	VENT-ROOF, NONPOWERED - 2" ROOF - JENSEN 7724 WHE
	064470-01-700	EA	COVER ROOF VENT, 7291
	110051-01-701	EA	GARNISH W/SCREEN & FRAME 2"
	110051-01-702	EA	HAND CRANK & OPERATOR ASM.
	110051-01-703	EA	HANDLE CRANK

VENTS & SHROUDS

KEY	PART NUMBER	U/M	DESCRIPTION
	083558-03-000	EA	VENT-PLUMBING PIPE ROOF, W/COVER - OFF WHITE
	083558-07-000	EA	VENT-PLUMBING PIPE ROOF, W/COVER - BRIGHT WHITE
	084073-03-000	EA	COVER-ROOF VENT, REFRIGERATOR - OFF WHITE - NORCOLD
	084073-07-000	EA	COVER-ROOF VENT, REFRIGERATOR - BRIGHT WHITE - NORCOLD
	084073-04-000	EA	BASE-ROOF VENT, REFRIGERATOR - BLACK - NORCOLD
	105028-01-000	EA	FLASHING ASM-VENT, REFRIGERATOR
	103385-01-01A	EA	VENT-RANGE HOOD, OUTSIDE - OFF WHITE - VENTLINE
	103385-01-02A	EA	VENT-RANGE HOOD, OUTSIDE - BRIGHT WHITE - VENTLINE

WINDOW, VENT & EXTERIOR DOOR GROUP (CONTINUED)**DINETTE WINDOW**

KEY	PART NUMBER	U/M	DESCRIPTION
	098647-36-01A	EA	WINDOW ASM-SLIDER, HORIZONTAL - W/OFF WHITE INSIDE FRAME
	098647-36-700	EA	WINDOW W/O TRIM
	098647-36-701	EA	TRIM
	098647-36-702	EA	GLASS-STATIONARY
	098647-36-703	EA	SLIDE ASSEMBLY
	098647-36-704	EA	SCREEN ASSEMBLY

PASSENGER SIDE BEDROOM WINDOW

KEY	PART NUMBER	U/M	DESCRIPTION
	098647-29-01A	EA	WINDOW ASM-SLIDER, HORIZONTAL - W/O INSIDE FRAME
	098644-01-700	EA	LATCH REPAIR KIT (BLACK)
	098644-01-706	FT	WEATHERSTRIP-GLASS
	098644-01-708	FT	CHANNEL-RUN, PIERCED - GLASS
	098644-01-710	FT	TRACK-SPACER, FOR SCREEN 12'
	098644-01-711	FT	WEATHERSTRIP-SCREEN, BLACK
	098644-01-713	EA	SCREEN CLIPS (METAL)(BLK)
	098644-01-716	FT	PLUG-FILLER
	098644-01-717	FT	SPLINE-SCREEN MFG

DRIVER SIDE BEDROOM WINDOW

KEY	PART NUMBER	U/M	DESCRIPTION
	098647-30-01A	EA	WINDOW ASM-SLIDER, HORIZONTAL - W/O INSIDE FRAME
	098644-01-700	EA	LATCH REPAIR KIT (BLACK)
	098644-01-706	FT	WEATHERSTRIP-GLASS
	098644-01-708	FT	CHANNEL-RUN, PIERCED - GLASS
	098644-01-710	FT	TRACK-SPACER, FOR SCREEN 12'
	098644-01-711	FT	WEATHERSTRIP-SCREEN, BLACK
	098644-01-713	EA	SCREEN CLIPS (METAL)(BLACK)
	098644-01-716	FT	PLUG-FILLER
	098644-01-717	FT	SPLINE-SCREEN MFG

DRIVER & PASSENGER CAB SIDE WINDOWS

KEY	PART NUMBER	U/M	DESCRIPTION
	103658-10-01A	EA	WINDOW-CAB, PASSENGER - W/INSIDE FRAME - EXCEL H373-ARR
	103658-09-01A	EA	WINDOW-CAB, DRIVER - W/INSIDE FRAME - EXCEL H373-ARL
	098644-01-700	EA	LATCH-REPAIR KIT
	098644-01-706	FT	WEATHERSTRIP, EXCEL 171-010668
	098644-01-710	FT	TRACK-SCREEN SPACER, 12' LENGTH - EXCEL M401-31
	098644-01-711	FT	WEATHERSTRIP-SCREEN, BLACK - EXCEL 171-016965
	098644-01-713	FT	SPRING-SCREEN FRAME (CLIP), PLASTIC - BLACK - EXCEL 226-016966
	098644-01-708	FT	CHANNEL-PIERCED RUN, EXCEL 122-016543
	098644-01-716	FT	PLUG-FILLER, EXCEL 132-014470
	098644-01-717	FT	SPLINE-SCREEN, EXCEL 132-004716

WINDOW, VENT & EXTERIOR DOOR GROUP (CONTINUED)

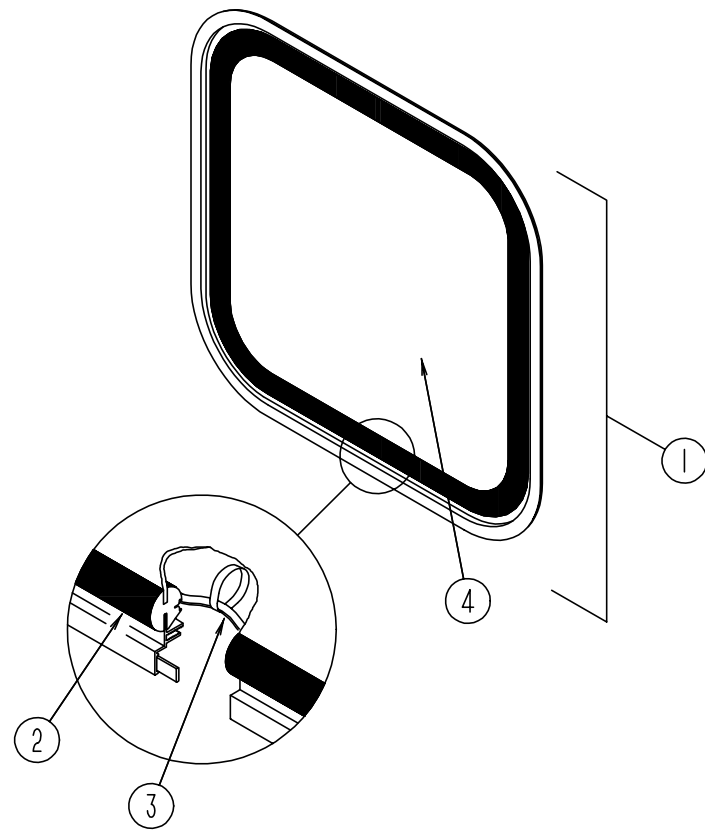

BACKWALL ESCAPE WINDOW

KEY	PART NUMBER	U/M	DESCRIPTION
1	078528-07-F15 074816-11-000	EA	WINDOW - ESCAPE - 27" X 48" - W/O INSIDE FRAME
2	002282-09-000	EA	WEATHERSTRIP - WINDOW .125" VULCANIZED - 163.06" LONG - BLACK
3	002285-01-000 102922-01-000	FT	FILLER - WEATHER STRIP RUBBER - BLACK
4	076337-13-000	EA	GLASS - WINDOW

WINDOW, VENT & EXTERIOR DOOR GROUP (CONTINUED)

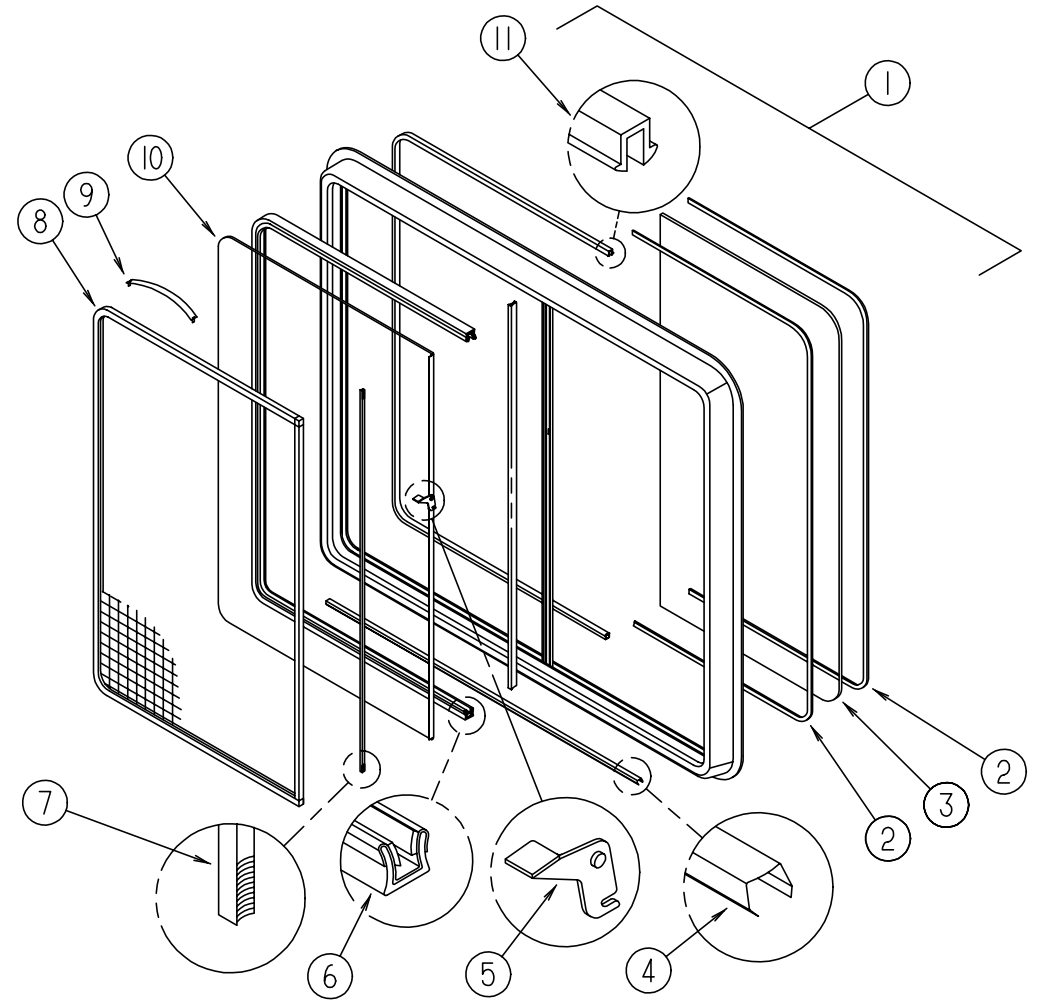

GALLEY SLIDING WINDOW

KEY	PART NUMBER	U/M	DESCRIPTION
1	098647-31-01A 098647-31-700 098647-31-701	EA	WINDOW-SLIDING W/OFF WHITE INSIDE FRAME - EXCEL H425-C1W66R
2	098644-01-705	EA	WINDOW-W/O INSIDE FRAME H425-C1R
3	098647-31-702	EA	INSIDE FRAME - OFF WHITE CW2966
4	098644-01-710	FT	GLAZING STRIP - EXCEL M926-12
5	098644-01-700	EA	GLASS-STATIONARY - EXCEL 096-019299
6	098644-01-708	FT	TRACK-SCREEN SPACER - 12' LENGTH - EXCEL M401-31
7	098644-01-711	EA	LATCH-REPAIR KIT - EXCEL B801-CK
8	098647-31-704	FT	CHANNEL-PIERCED RUN - EXCEL 122-016543
9	098644-01-713	EA	WEATHERSTRIP-SCREEN - BLACK - EXCEL 171-016965
10	098647-31-703	EA	SCREEN W/WEATHERSTRIP & FRAME SPRING (CLIP) - EXCEL 410-019128
11	098644-01-706 098644-01-716 098644-01-717	EA	SPRING-SCREEN FRAME (CLIP) - PLASTIC - BLACK - EXCEL 226-016966
		FT	WEATHERSTRIP - EXCEL 171-010668
		FT	PLUG-FILLER - EXCEL 132-014470
		FT	SPLINE-SCREEN - EXCEL 132-004716

WINDOW, VENT & EXTERIOR DOOR GROUP (CONTINUED)

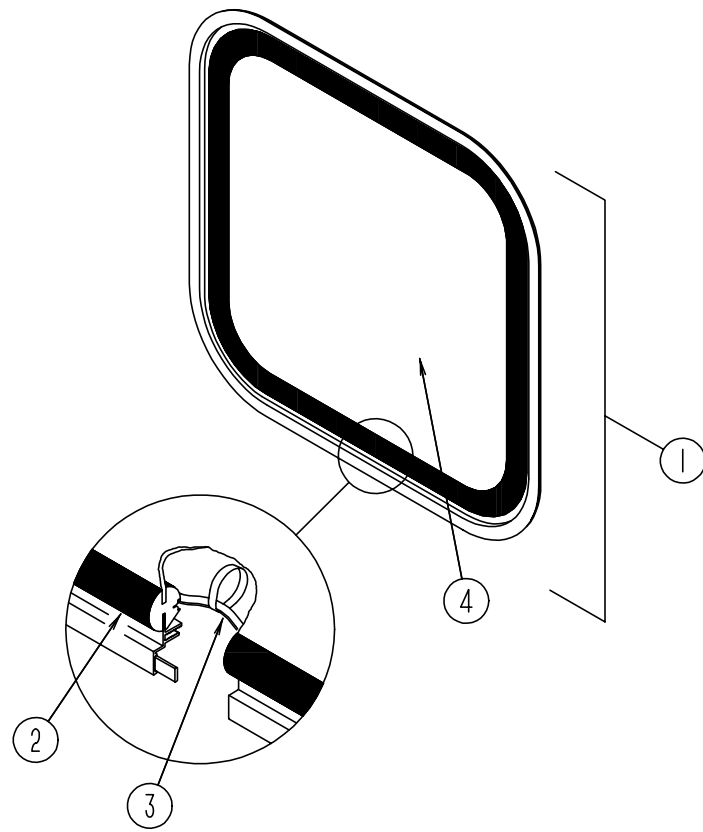

ESCAPE WINDOW

KEY	PART NUMBER	U/M DESCRIPTION
	074816-11-000	EA INSIDE FRAME- WINDOW - OFF WHITE
1	078528-07-F15	EA WINDOW-ESCAPE - W/O INSIDE FRAME
2	076337 13 000	EA GLASS-EGRESS 1157 X 54
3	002285-01-000	FT FILLER-WEATHER STRIP - RUBBER - BLACK
4	002282-09-000	EA WEATHERSTRIP-.125" X 133.25" - BLACK
	077066-01-702	EA TAPE ASM-ESCAPE WINDOW - RED

WINDOW, VENT & EXTERIOR DOOR GROUP (CONTINUED)

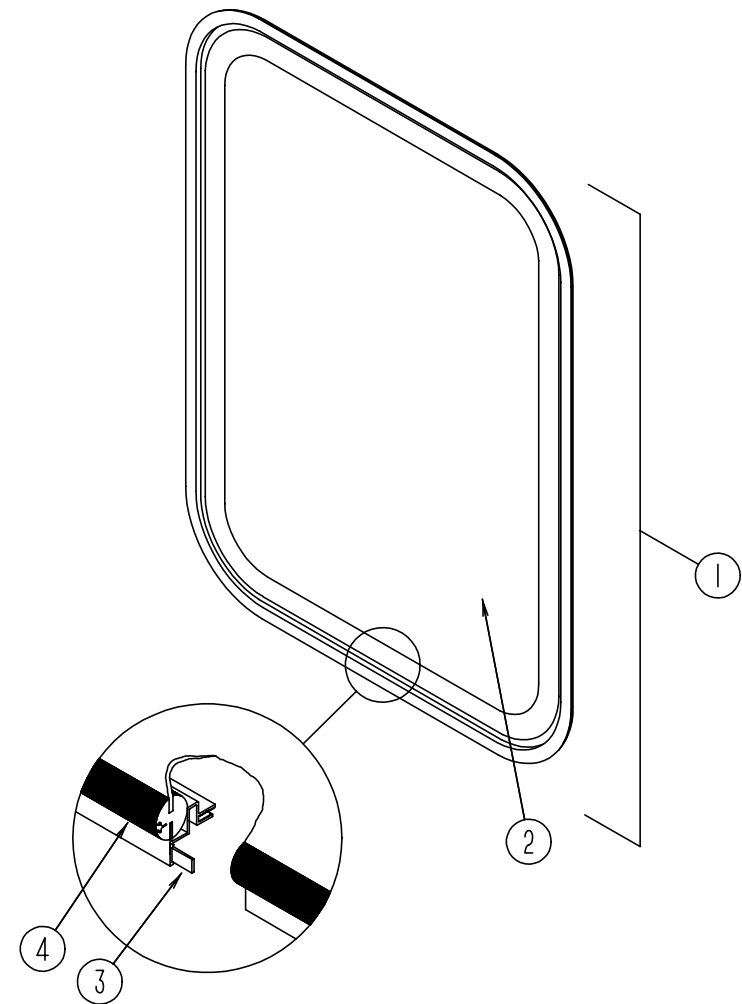

ENTRY DOOR WINDOW

KEY	PART NUMBER	U/M DESCRIPTION
	067609-38-000	EA FRAME-WINDOW - ENTRY DOOR - OFF WHITE
1	079733-17-F15	EA WINDOW-ENTRANCE DOOR - GLASS
2	002181-24-000	EA GLASS-WINDOW, PICTURE 687.4 X 449.4 CLEAR 90%
3	069640-11-000	FT SEALER-TAPE - 3/16" X 3/8" BLACK
4	087561-01-000	FT SEAL-GLASS - EXTERIOR - .5" WIDE - VINYL - BLACK
	050216-02-000	FT SPLINE-GLASS - EXTERIOR - VINYL - .19" - BLACK

WINDSHIELD & WIPER GROUP

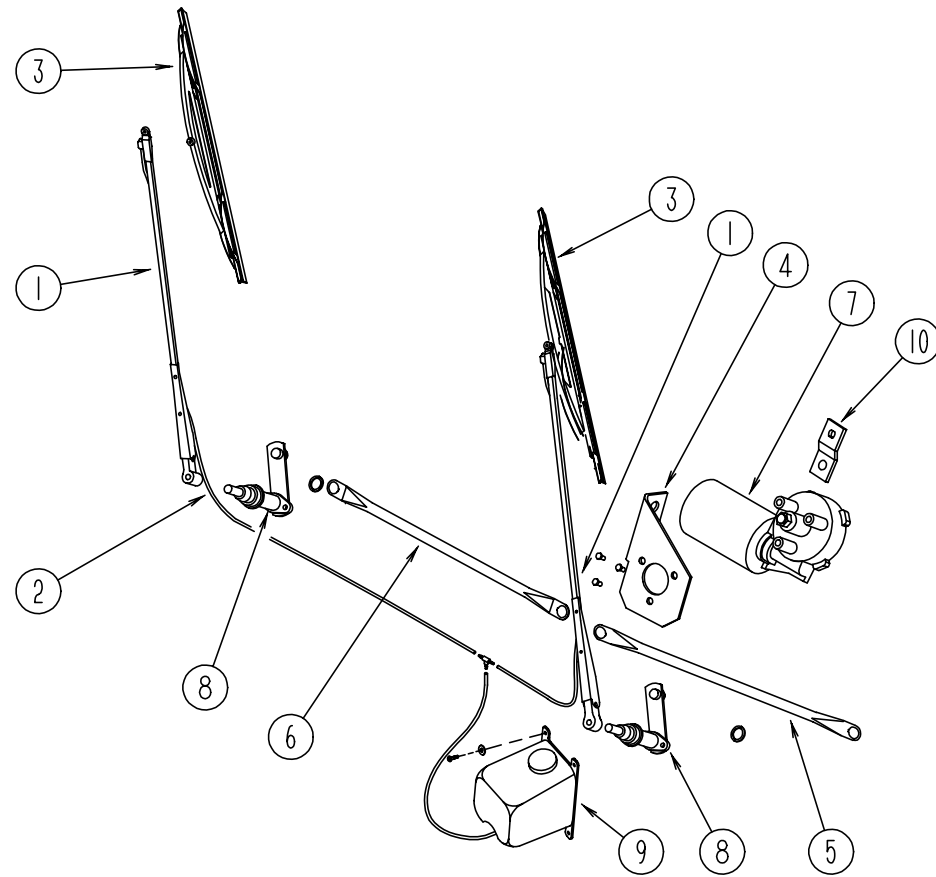

WIPER COMPONENTS

KEY	PART NUMBER	U/M	DESCRIPTION
1	103671-01-000	EA	ARM-WIPER - 24" - UT 52179-20LE27WC
2	096931-01-700	EA	HOSE-WIPER - TO BLADE
	096931-01-701	EA	NOZZLE-HARDWARE KIT - INCLUDES NOZZEL,NUT,SCREWS AND PLASTIC CAP
	110742-01-000	EA	GASKET-WIPER
3	095964-01-000	EA	BLADE-WIPER - WINDSHIELD - 24"
	095964-01-700	EA	BLADE-REFILL 24" (PAIR) - 12360
4	104549-01-000	EA	BRACKET ASM-WIPER
4	103726-01-000	EA	BRACKET-MOTOR - WIPER
	096526-01-000	EA	SCREW-HEX - 1/4 - 28
5	103672-01-000	EA	LINK ASM-CONNECTING - 21.85" - DRIVER SIDE - 62506-20-LK25WJ
6	103672-02-000	EA	LINK ASM-CONNECTING 21.85 - PASSENGER SIDE - 62539-20-LK25WJ
7	104346-02-000	EA	MOTOR-WIPER - 63098-20-M012WJ
8	096505-07-000	EA	PIVOT SHAFT ASM - PASSENGER - 62901-20-SH25WJ
8	096505-08-000	EA	PIVOT SHAFT ASM - DRIVER SIDE - 62900-20-SH25WJ
9	056000-04-000	EA	WASHER-WINDSHIELD - BOTTLE & PUMP
	056000-01-700	EA	VACUUM HOSE 7/64 - 5/32
10	104347-01-000	EA	ARM-DRIVE - WIPER MOTOR - 1.54" - 62543-20-LE25WJ
	110178-01-000	EA	HOUSING-WIPER MOTOR - UT6237440-EC25WJ
	067188-01-000	EA	STUD-CRANK - WIPER - WINDSHIELD - AMBAC 1903424SD27WC
	061603-01-000	EA	GROMMET-SNAP - 3/16" ID - 3/8" HOLE - HEYCO SB-375-3

WINDSHIELD & WIPER GROUP (CONTINUED)

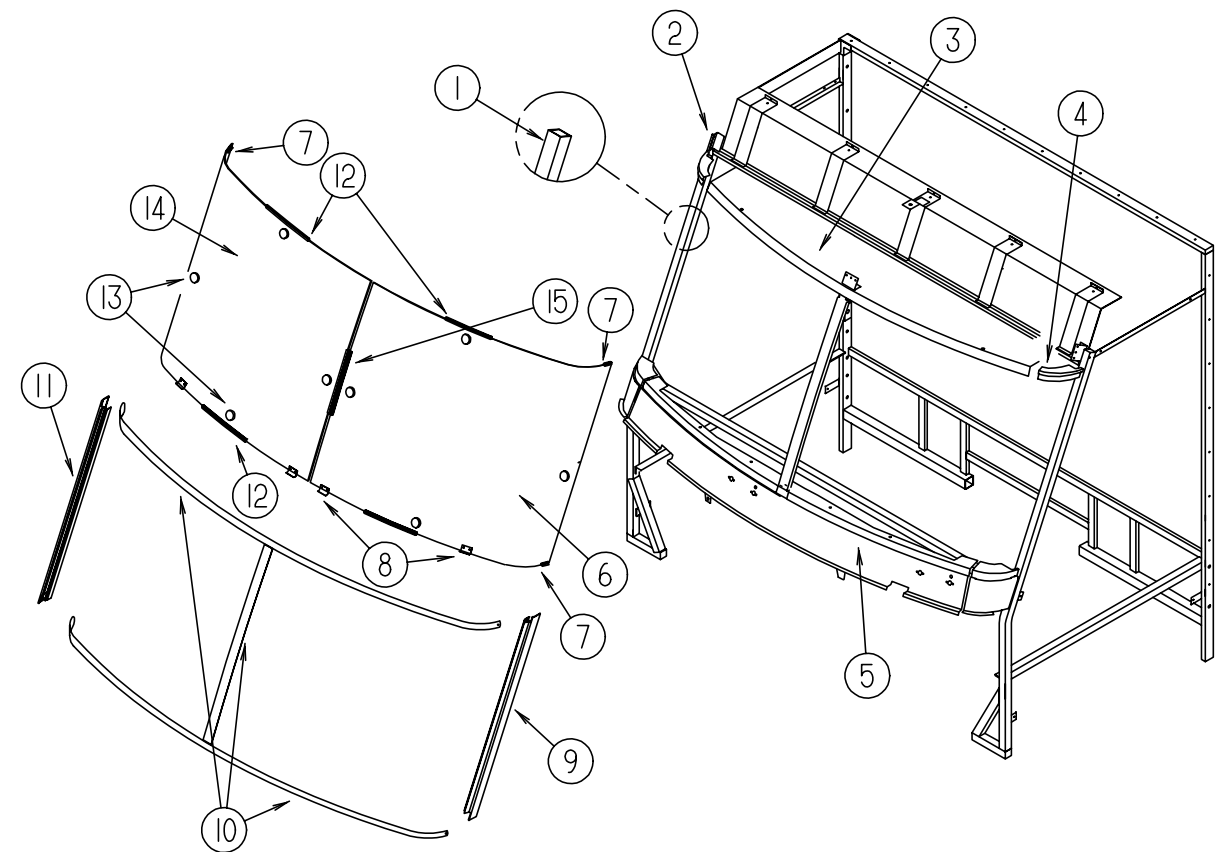

WINDSHIELD MOLDINGS & GLASS

KEY	PART NUMBER	U/M	DESCRIPTION
1	098788-06-000	EA	CHANNEL - 49" PCV
2	077922-03-000	EA	HEADER-WINDSHIELD - RIGHT END
3	077922-05-000	EA	HEADER-WINDSHIELD - CENTER
4	077922-04-000	EA	HEADER-WINDSHIELD - LEFT END
5	077847-02-000	EA	SUPPORT-WINDSHIELD - LOWER - W/O BRACKETS
6	088793-04-000	EA	GLASS-WINDSHIELD - DRIVER
7	102935-08-000	EA	WINDSHIELD CARRIER - 2"
8	104449-01-000	EA	SUPPORT-WINDSHEILD
9	103107-02-01A	EA	TRIM-WINDSHIELD - SIDE BLACK
10	102936-01-000	FT	MOLDING-REVEAL - WINDSHEILD
11	103107-01-01A	EA	TRIM-WINDSHIELD - SIDE BLK
12	110268-07-000	EA	WINDSHIELD CARRIER - 42.1"
13	081914-01-000	EA	BUMPER-RUBBER - ROUND - .43" DIAMETER - BLACK
14	088793-03-000	EA	GLASS-WINDSHIELD - PASSENGER
15	110268-02-000	EA	WINDSHIELD CARRIER - 38"